

Submersible drainage pump J MEX (MSHA)

Submersible drainage pumps J 10 - 350 MEX are approved explosion proof mine pumps suitable for pumping water and dirty water mixed with light abrasive soil. Approved MSHA (Mine Safety and Health Administration) and D.O.E.R. (Pennsylvania Department of Environmental Resources). Applications include gassy coal mines, tunnels, strip mines, and quarries where MSHA permissibility is required.

Convenient handling – designed to make your life easier

Lightweight silumin parts makes transport, handling and installation easy.

Reliability

Compact design with durable silumin housing and mechanical shaft seals in silicon carbide provide a pump that you can rely on. Seal minder moisture detector protects the pump if seal leakage occur.

Reliable operation – minimizes time for maintenance

Double outer casing and good heat transfer enables pump to operate continuously at low levels or even run dry without damaging the motor. Thermal overload protection shuts off the pump upon an overtemp. condition.

Wear resistance – one investment, years of cost efficient pumping

Stainless steel impeller, shaft and hardwear as well as adjustable wear parts in oil resistant nitrile rubber provide a long life and high efficiency.

Robust design

Rigid stainless steel shaft with heavy duty bearings gives vibration free operation.

Complete supply – MSHA approved pump and panel

All J MEX series are equipped with MSHA approved power cable and are supplied with a manual or automatic control panel.

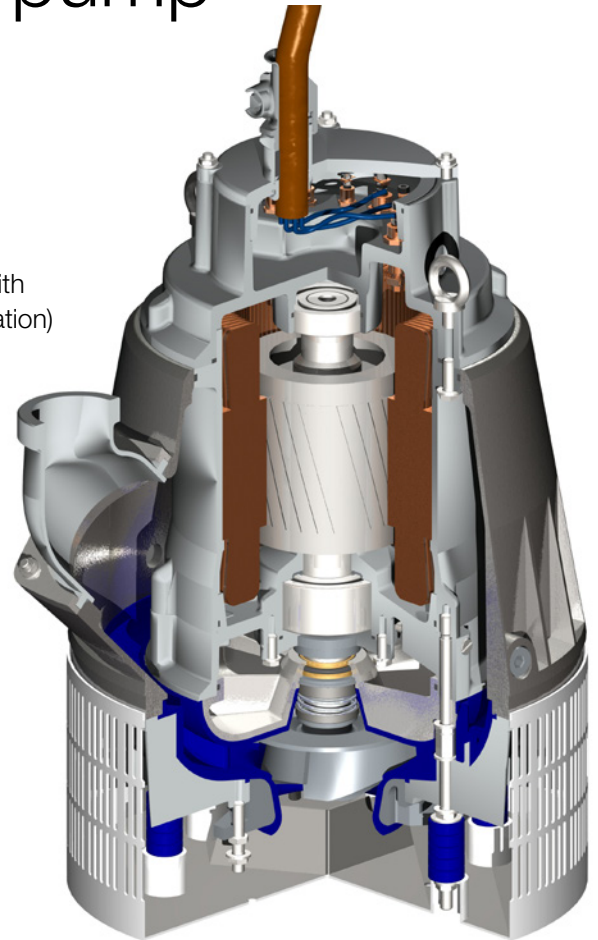

Submersible drainage pump J 10B MEX

J 10B MEX	3-phase
Motor rating P2	1.8 Hp
Voltage (V)	Dual 230/460 or 575
Full load amps (A)	Dual 7.0/3.5 or 2.8
Speed	3'450 rpm
Free passage	3/16" x 3/4"
Discharge connections	Thread NPT 2", 3"
Weight (excl. cable)	77 lb.
Motor protection	Thermal overload sensors
Electric cable	50 ft.

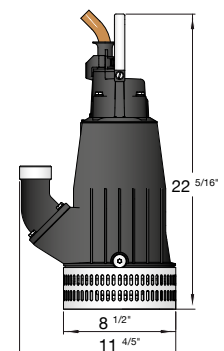
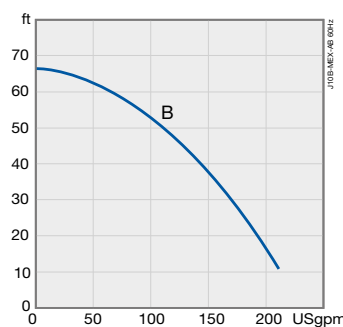

Submersible drainage pump J 20B MEX

J 20B MEX	3-phase
Motor rating P2	3.6 Hp, 3 ~
Voltage (V)	460 or 575
Full load amps (A)	5.4 or 4.3
Speed	3'450 rpm
Free passage	3/16" x 3/4"
Discharge connections	Thread NPT 2", 3"
Weight (excl. cable)	77 lbs
Motor protection	Thermal overload sensors
Electric cable	50 ft.

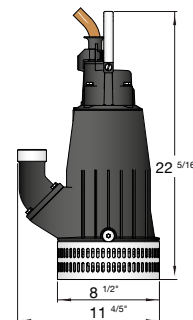
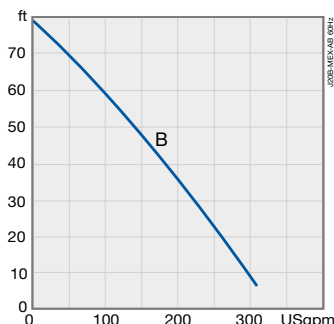

Submersible drainage pump J 50B MEX

J 50BHH MEX	3-phase
J 50BHV MEX	3-phase
Motor rating P2	8.2 Hp, 3 ~
Voltage (V)	460 or 575
Full load amps (A)	10.3 or 8.2
Speed	3'450 rpm
Free passage	1/4" x 1 5/16"
Discharge connections	Thread NPT 3", 4"
Weight (excl. cable)	120 lb.
Motor protection	Thermal overload sensors
Electric cable	50 ft.

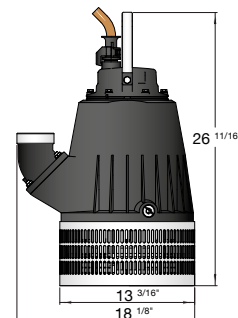
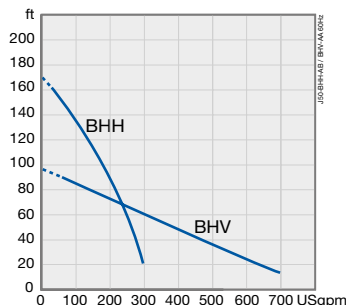

Submersible drainage pump J 80B MEX

J 80BHH MEX	3-phase
J 80BHV MEX	3-phase
Motor rating P2	13.6 Hp, 3 ~
Voltage (V)	460 or 575
Full load amps (A)	16.2 or 13.0
Speed	3'450 rpm
Free passage	1/4" x 1 5/16"
Discharge connections	Thread NPT 3", 4", 6"
Weight (excl. cable)	177 lb.
Motor protection	Thermal overload sensors
Electric cable	50 ft.

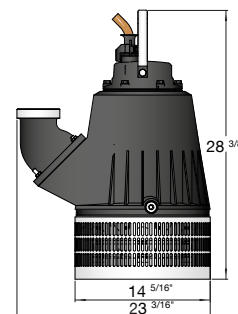
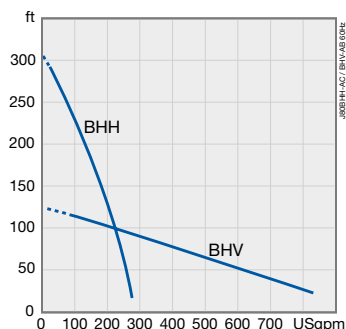

Submersible drainage pump J 200B MEX

J 200BHV MEX	3-phase
J 200BHH MEX	3-phase
Motor rating P2	31.3 Hp, 3 ~
Voltage (V)	460 or 575
Full load amps (A)	38.2 or 30.6
Speed	3'450 rpm
Free passage	1/4" x 2"
Discharge connections	Thread NPT 4", 6"
Weight (excl. cable)	377 lb.
Motor protection	Thermal overload sensors
Electric cable	50 ft.

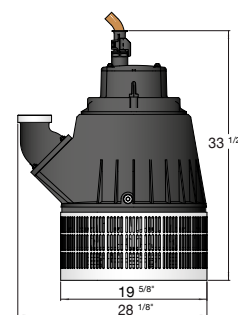
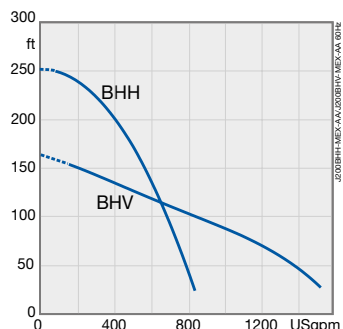

Submersible drainage pump J 350B MEX

J 350HH MEX	3-phase
Motor rating P2	59.8 Hp, 3 ~
Voltage (V)	460 or 575
Full load amps (A)	69 or 55.2
Speed	3'550 rpm
Free passage	1/4" x 2"
Discharge connections	Thread NPT 4", 6"
Weight (excl. cable)	498 lb.
Motor protection	Thermal overload sensors
Electric cable	50 ft.

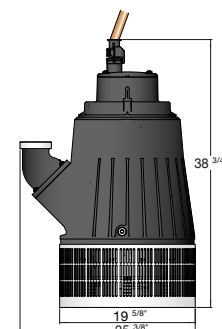
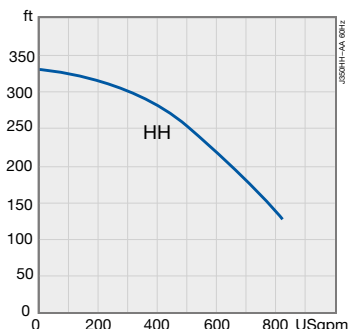

www.sulzer.com

E10417 us 2.2021, Copyright © Sulzer Ltd 2021

This brochure is a general product presentation. It does not provide any warranty or guarantee of any kind. Please, contact us for a description of the warranties and guarantees offered with our products. Directions for use and safety will be given separately. All information herein is subject to change without notice.