

SULZER

Chemtech

Random packing – from competitive products to advanced solutions



Mass transfer technology

Your partner in separation & mixing technology

The highest level of application know-how

Our team provides expert knowledge for more than 500 applications in 100 processes, enabling us to optimize the performance and your installation.

Fast and reliable turnaround services

We don't shut-down, when you shut-down. You can rely on Sulzer professionals, expertise and procedures to get you back and running in the shortest possible time.

Comprehensive engineering and technology services

We provide a full scope of associated engineering and technology services to optimize or trouble-shoot your installation.



A broad range of innovative and high-performing products

More than 200 of our products cover a wide range of needs in the field of separation and mixing technology.

They have proven their performance in more than 100'000 columns, 50'000 gas/liquid or liquid/liquid separators and 100'000 static mixers in operations worldwide.



**MellapakPlus™
Packing**

Often copied, never
equaled



**UFMPPlus™
trays**

One of the best high
performance trays
ever tested at FRI



NeXRing™

The next big thing in
random packing



**SMV™
static mixer**

High mixing efficiency
combined with large
turn-down processing
capabilities



**Dusec Plus™
Coalescer**

High performance
liquid/liquid
coalescer

Random packing

Random packing has been used for fractionation, absorption and stripping operations in gas, refinery and chemical plants for many years and the benefits are well established. For example, in high liquid load and high pressure applications random packing has been historically preferred as it provides improved distillation or absorption efficiency and a reduced pressure drop.

Furthermore, ease of replacement and storage make random packing the ideal choice for systems with heavy fouling or corrosion where packing is frequently replaced.

With our NeXt evolution of random packing we bring the same or better performance of the established random packing types which when combined with Sulzer's leading application know-how offers a reduction in both capital and operation cost of even your most demanding processes.

Sulzer's broad established random packing portfolio includes Nutter Rings, I-Rings, C-Rings, P-Rings, R-Rings and S-Rings, and gives us the flexibility to offer the solution whatever your requirement.

NeXRing random packing	4
NeXRing comparison	6
NeXRing applications	7
Nutter rings random packing	8
Other random packings	10
Column internals	12

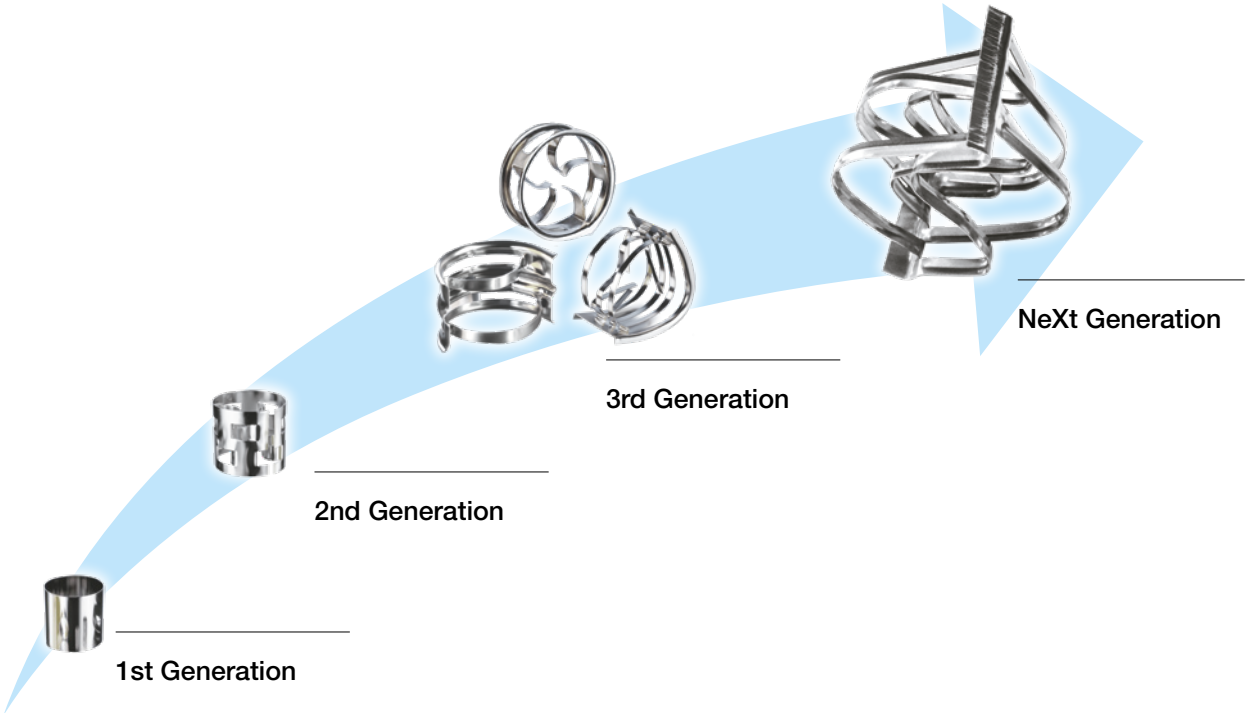

NeXRing™

The NeXt generation random packing



The NeXRing is the latest high performance random packing developed by Sulzer. The NeXRing provides extremely large and uniform open area in every ring orientation allowing a high surface exposure to liquid and vapor while minimizing dry zones.

The NeXRing had been tested in both Sulzer's leading in-house R&D facilities and independently. NeXRing #1.2 had been successfully tested in FRI in 2017. All results have shown improved hydraulic performance compared to established random packing types with the same efficiency.

HETP of NeXRing

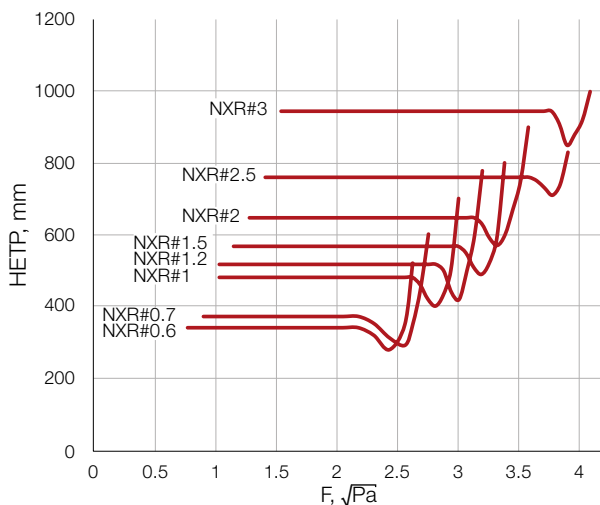

Conditions

Valid for atmospheric distillation with standard organic test mixture at total reflux

The NeXRing has:

- Reduced pressure drop
- Increased capacity
- Improved mechanical stability
- Improved anti fouling feature

The NeXRing enables you to:

- Reduce operating costs
- Reduce column size (greenfield)
- Increase capacity (brownfield)
- Increase efficiency
- Increase running time and reduce stoppage

Pressure drop performance curves

Liquid load L , $m^3/(m^2h)$, Air-water system, ambient conditions

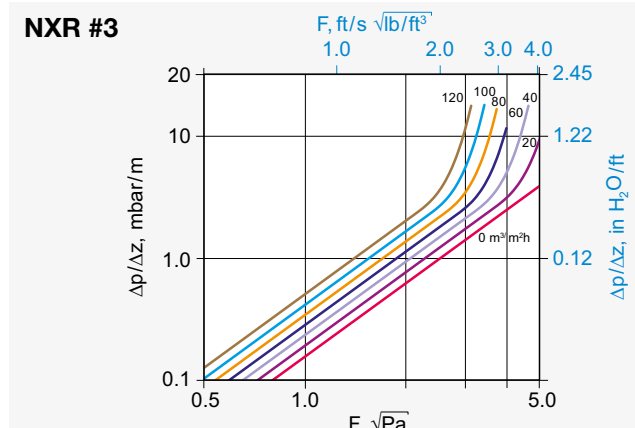
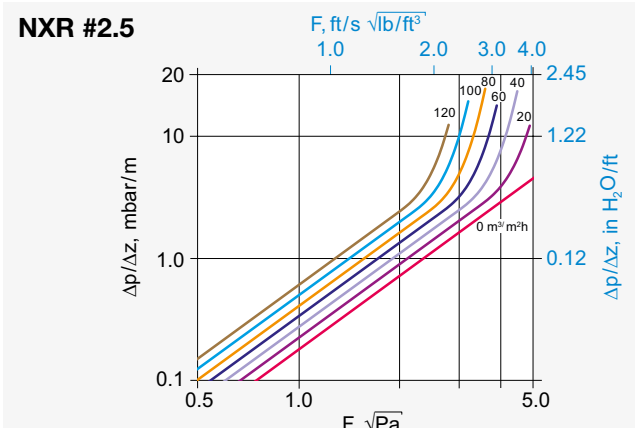
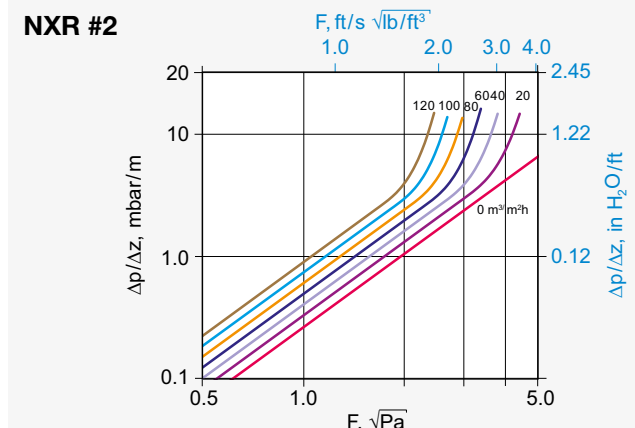
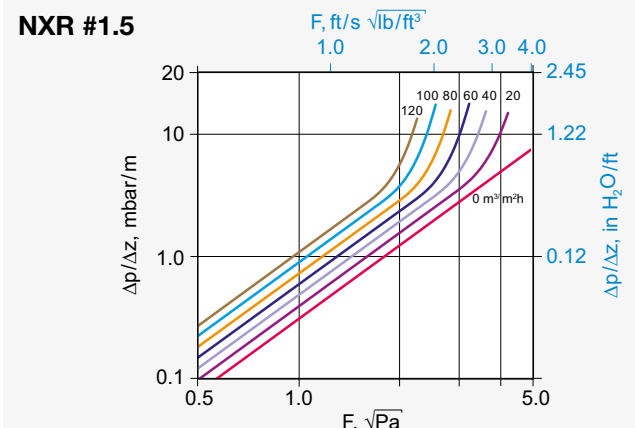
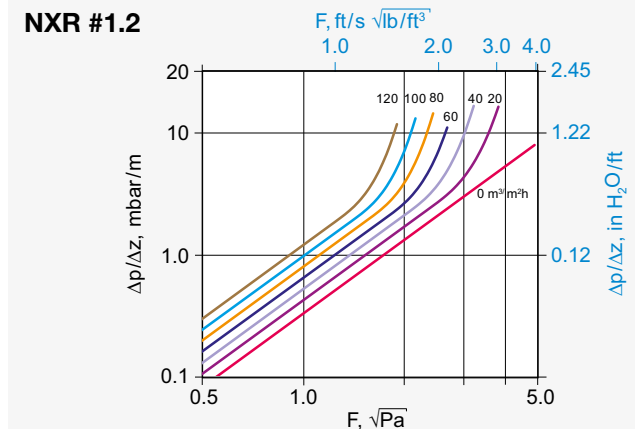
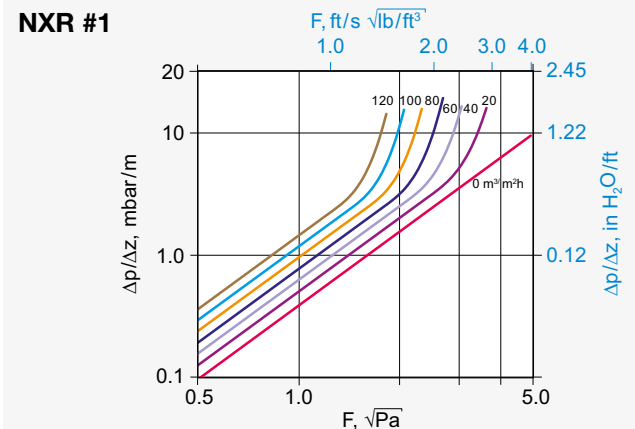
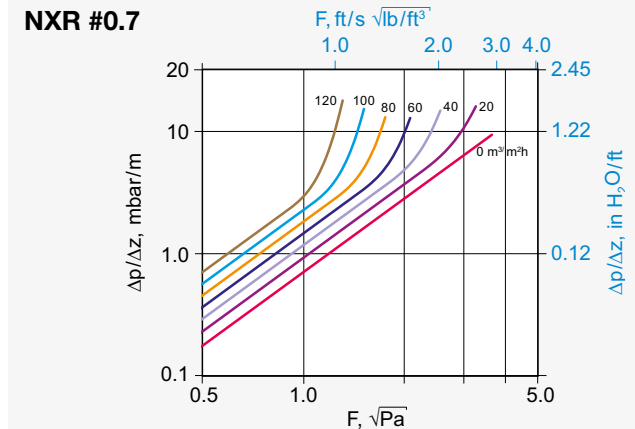
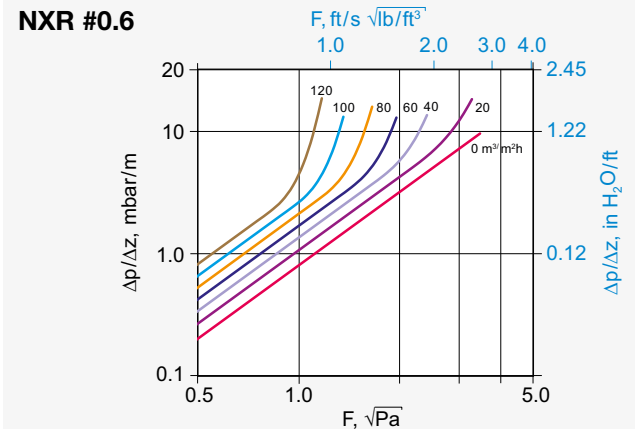

NeXRing™

The NeXt generation random packing

Sulzer's NeXRing demonstrates an improvement of performance in comparison to the widely used P-Ring (direct replacement of Pall Ring) and I-Ring (direct replacement of IMTP Ring).

- Replacing P-Ring#2 with NeXRing#1.5 will give up to 10% increase in efficiency and a 25% increase in capacity. If NeXRing#2 is used, up to a 35% increase in capacity is obtained with the same efficiency
- By replacing I-Ring #40 with NeXRing#1.2, more than 10% increase in capacity can be achieved while keeping the same efficiency. For applications asking for more efficiency, NeXRing #1 can be a good choice while still bringing certain capacity improvement.
- I-Ring #50 can be replaced by NeXRing #2 for a 10% increase in capacity with no decrease in efficiency. NeXRing #1.5 can be used for a further increase in efficiency.

P-Ring™



I-Ring™



NeXRing™



Influence of ring type and size to efficiency and capacity

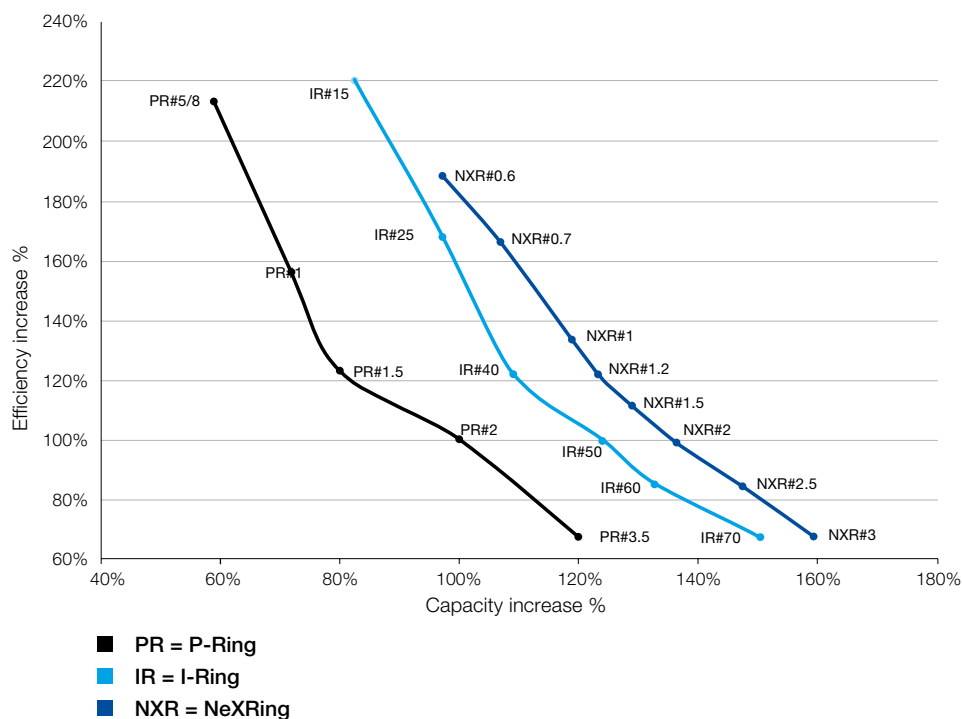

Conditions of the test

Test mixture: ethylbenzene and chlorobenzene, at atmospheric pressure under total reflux condition

The graphic shows relative efficiency values and relative capacity values for different P-Rings, I-Rings and NeXRings. The P-Ring #2 is a standard in the industry. That's why it was set as a reference point (100% efficiency and 100% capacity).

CMR™ is a trademark and IMTP® and Cascade Mini-Rings® are registered trademarks of Koch-Glitsch LP. Pall Ring® is a registered trademark of BASF AG. Raschig Super-Ring® is a registered trademark of Raschig GmbH.

Applications

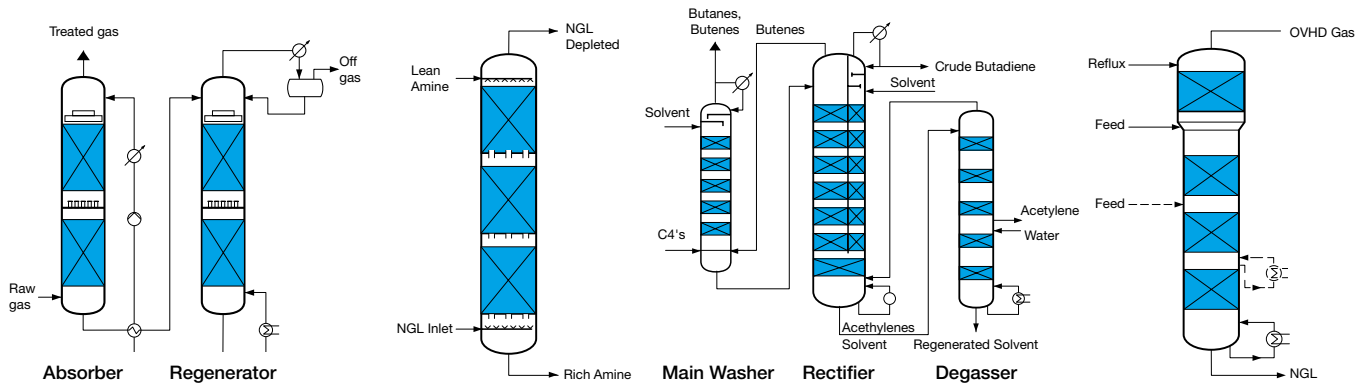

Fertilizer, Acid Gas removal, Gas sweetening

Random packing is widely used in the removal of CO_2 and H_2S from natural or bio-gas by contacting with amine based solvents such as MEA, DEA, MDEA and Activated MDEA. A common characteristic of these solvents is the strong tendency to foam.

The Sulzer NeXRing can provide capital and operational cost reductions in these applications by giving a much lower pressure drop compared to older random packing types minimizing the hydraulic impact of foam. Sulzer's NeXRing can directly replace existing previous generations of random packing either to hydraulically debottleneck the column or to increase the column efficiency by using a smaller ring size while keeping the same pressure drop.

NGL (Natural Gas Liquids) treatment

NGL produced from liquids recovery plants contain H_2S , CO_2 and mercaptans which need to be removed to satisfy gas purity requirements. Random packing is the industry standard for this application and the Sulzer NeXRing with its uniform surface area distribution and high open area helps to create a more uniform droplet dispersal compared to previous generation random packing while also minimizing the potential for back-mixing.

Replacing existing older types of random packing with Sulzer NeXRings combined with Sulzer's high performance VSX continuous and dispersed phase distributors provides either an increased efficiency or increased capacity.

Butadiene

In butadiene production random packing is typically used in the main wash, rectifier and degasser columns due to their characteristically high specific liquid load.

Replacing previous generation of random packing with the equivalent Sulzer NeXRing can lead to higher capacities without loss of efficiency. In these unit operations it is fairly common to use dividing wall columns. To prevent loss of efficiency or hydraulic performance a good understanding of a liquid distribution is critical. With many dividing wall columns in successful operation and a track record of performance since the 1960's Sulzer can provide this critical and often missed design know-how to get the most out of your column.

Demethanizers

Separation of methane from heavy hydrocarbons is done at high operating pressure and low temperature. Due to the low surface tensions and small density differences leading to unstable liquid films ensuring good contact between the liquid and gas phase is critical.

Due to these characteristics random packing is typically preferred for demethanizer applications in comparison to trays or structured packing. The Sulzer NeXRing with its higher capacity and lower pressure drop enables a further increase in capacity for existing columns or decreased diameters and bed heights for new columns.

Nutter Ring™



- High-performance random packing designed by Dale Nutter in 1984
- Efficiency enhanced by lateral liquid spreading and surface film renewal
- Superior surface utilization allows for shorter packed beds
- Intensively tested by Fractionation Research Institute (FRI) which makes the Nutter Ring the best-known high-performance random packing in industry
- Geometry provides maximum randomness with minimum nesting and maximum mechanical strength

Nutter Ring types		NR #0.7	NR #1	NR #1.5	NR #2	NR #2.5	NR #3
Specific surface	m ² /m ³	226	170	124	96	85	66
	ft ² /ft ³	68.9	51.8	37.8	29.3	25.9	20.1
Void fraction	%	98	98	98	98	98	98

Material thickness can be adjusted to clients' needs. Other sizes are available on request.

HETP of Nutter Ring

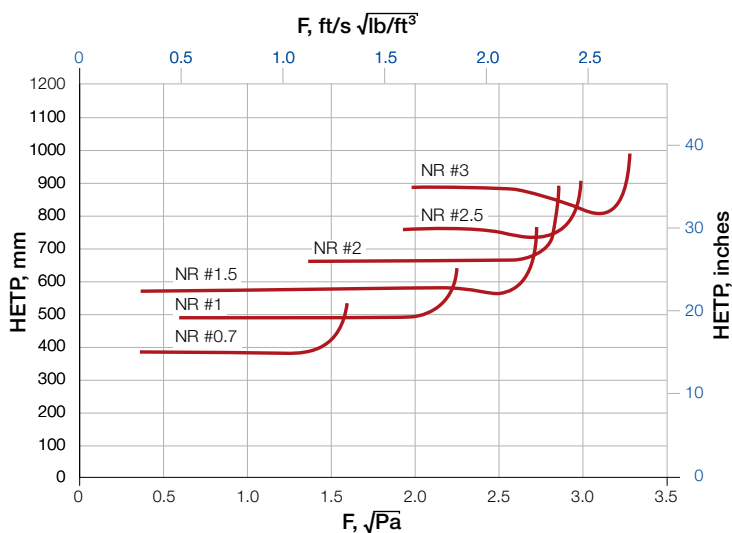

Conditions

Valid for atmospheric distillation with standard organic test mixture at total reflux

Pressure drop performance curves

Liquid Load L , $m^3/(m^2h)$, Air-water system, ambient conditions

—	0	20	40	60
—	80	100	120	150

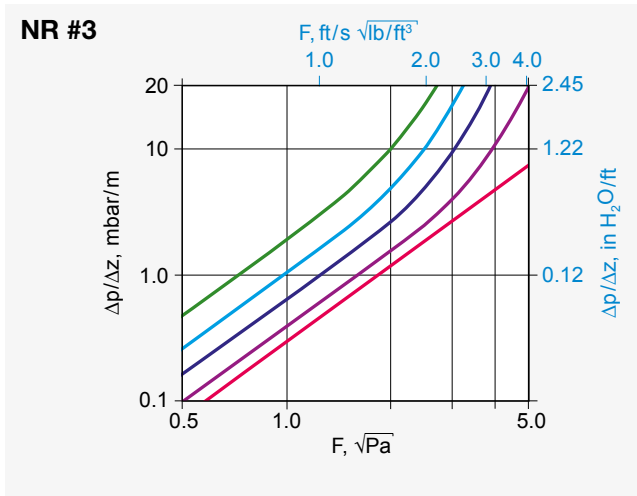
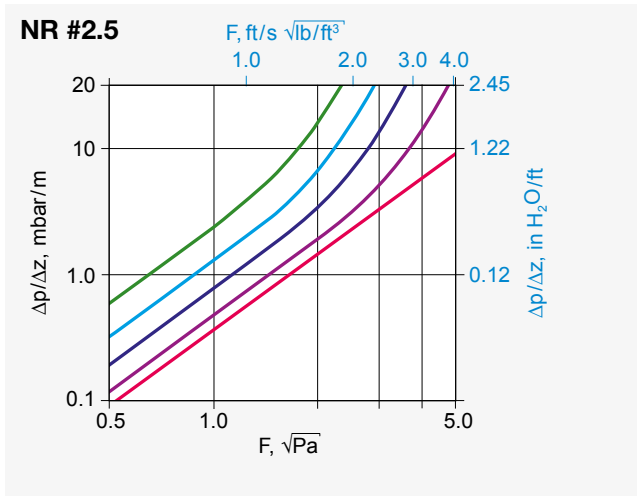
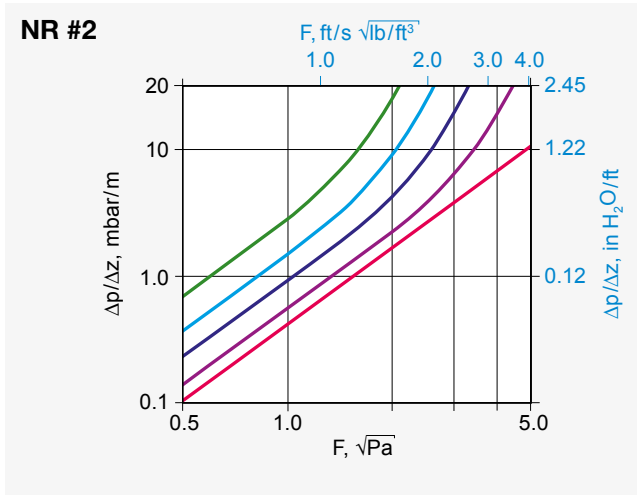
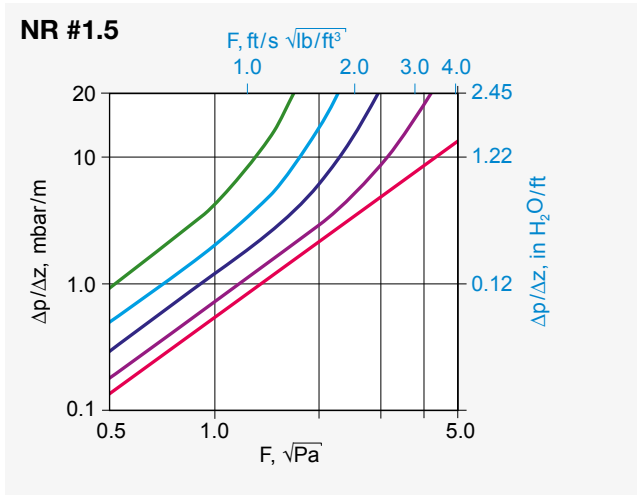
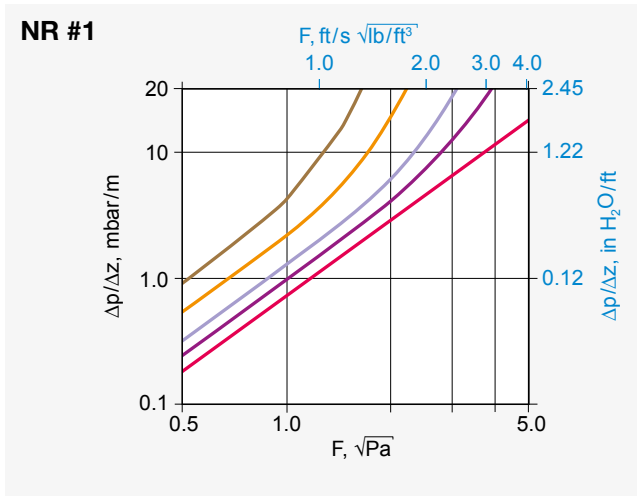
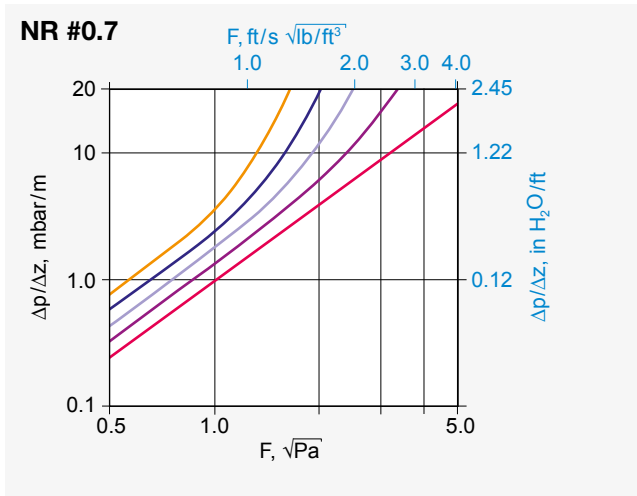

I-Ring™



- Equivalent to IMTP Rings - industry's first and most widely used high-performance random packing introduced in the late 1970s
- Geometry ensures low liquid hold-up and a great improvement in capacity compared to Pall Rings

I-Ring types		IR #15	IR #25	IR #40	IR #50	IR #60	IR #70
Specific surface	m ² /m ³	305	226	151	100	80	60
	ft ² /ft ³	93.0	68.9	46.0	30.5	24.4	18.3
Void fraction	%	97	97	98	98	98	98

Material thickness can be adjusted to clients' needs. Other sizes are available on request.

S-Ring™



- Direct replacement of widely used Raschig Super Ring
- Improved performance compared to 3rd generation random packings

S-Ring types		SR #0.3	SR #0.5	SR #0.6	SR #0.7	SR #1	SR #1.5	SR #2	SR #3
Specific surface	m ² /m ³	315	250	215	180	150	120	100	80
	ft ² /ft ³	96	76	65.5	54.5	45.7	36.5	30.5	24.4
Void fraction	%	96	97	97	98	98	98	98	98

Material thickness can be adjusted to clients' needs. Other sizes are available on request.

C-Ring™



- Equivalent to the widely used Cascade Mini-Rings (CMR)
- Evolution of Pall Ring employing a much lower diameter-to-height ratio which favors orientation that results in lower pressure drop and higher capacity
- Excellent mechanical strength
- C-Rings excel in fouling media

Also available in Plastic
Materials available are PP, PVC/C, PE, PVDF, ETFE, PFA

C-Ring types		CR #1	CR #1.5	CR #2	CR #2.5	CR #3	CR #4	CR #5
Specific surface	m ² /m ³	244	187	142	126	101	70	62
	ft ² /ft ³	74.4	57.0	43.3	38.4	30.8	21.3	18.9
Void fraction	%	97	97	98	98	98	98	99

Material thickness can be adjusted to clients' needs. Other sizes are available on request.

P-Ring™



- Equivalent to the widely used Pall Ring
- Design by BASF AG around 1940 based on the Raschig Ring
- Punched «shovels» leave «windows» on the outside facilitating vapor flow and enhancing capacity versus the R-Ring
- World's largest collection of performance data is available for the Pall Ring

Also available in Plastic
Materials available are PP, PVC/C, PE, PVDF, ETFE, PFA

P-Ring types		PR #5/8	PR #1	PR #1.5	PR #2	PR #3.5
Specific surface	m ² /m ³	350	222	144	112	64
	ft ² /ft ³	106.7	67.7	43.9	34.1	19.5
Void fraction	%	95	95	97	97	98

Material thickness can be adjusted to clients' needs. Other sizes are available on request.

Column Internals

Liquid distributors

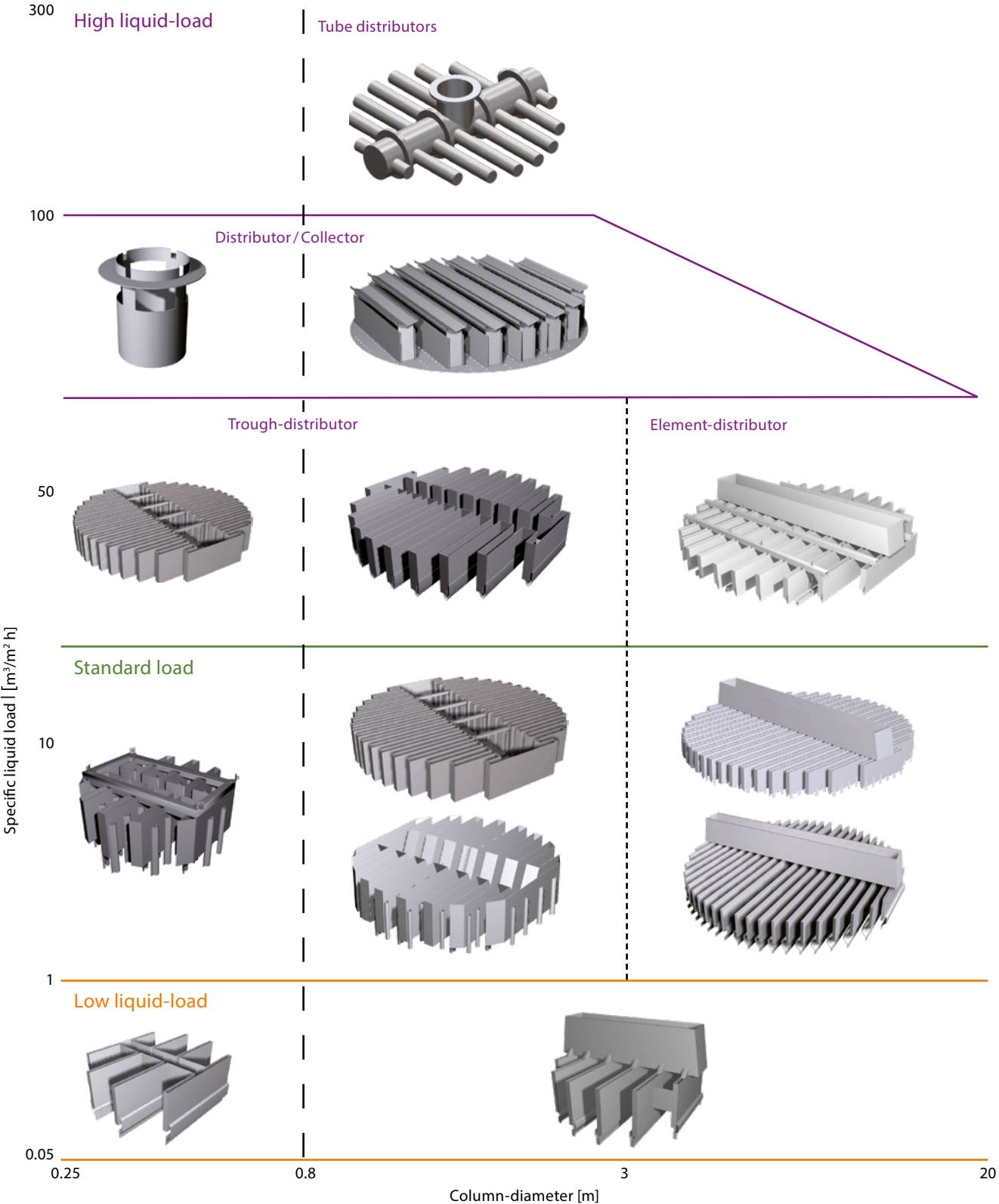

Internals for random packing columns

The Sulzer high performance liquid collector/re-distributor is designed with combination of high performance liquid distributor and vane type liquid collector.

Compared to the conventional liquid collector/re-distributor, it has the following advantages:

- Lower pressure drop
- Excellent liquid distribution also to small liquid loads (from $1 \text{ m}^3/(\text{m}^2\text{h})$)
- Possible to have high distribution density
- Improved liquid-mixing
- Minimized liquid leakage
- Reduced space requirement

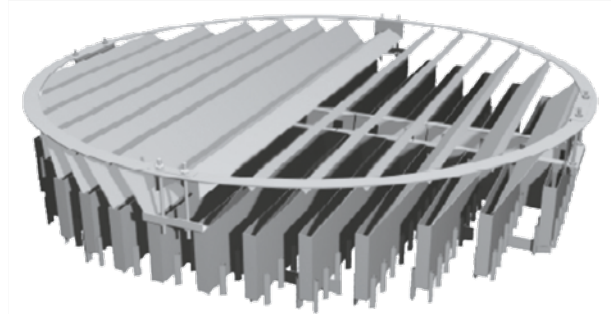

Support grids



Collectors

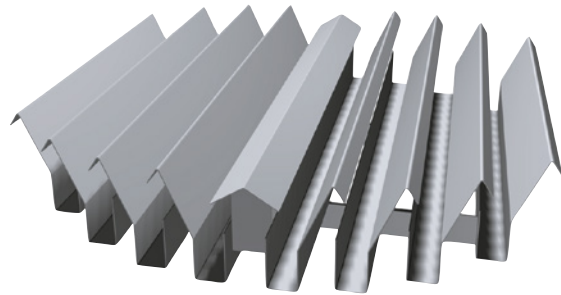

Collector-distributor systems/Vapor distributor

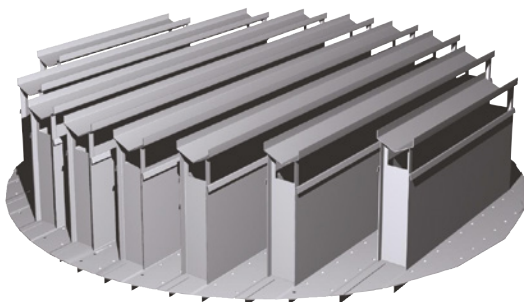

Chimney trays

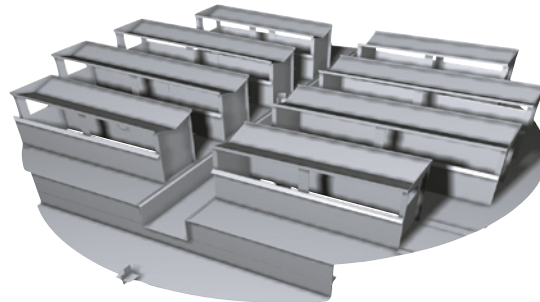

Internals for random packing columns

Column internal for NeXRing

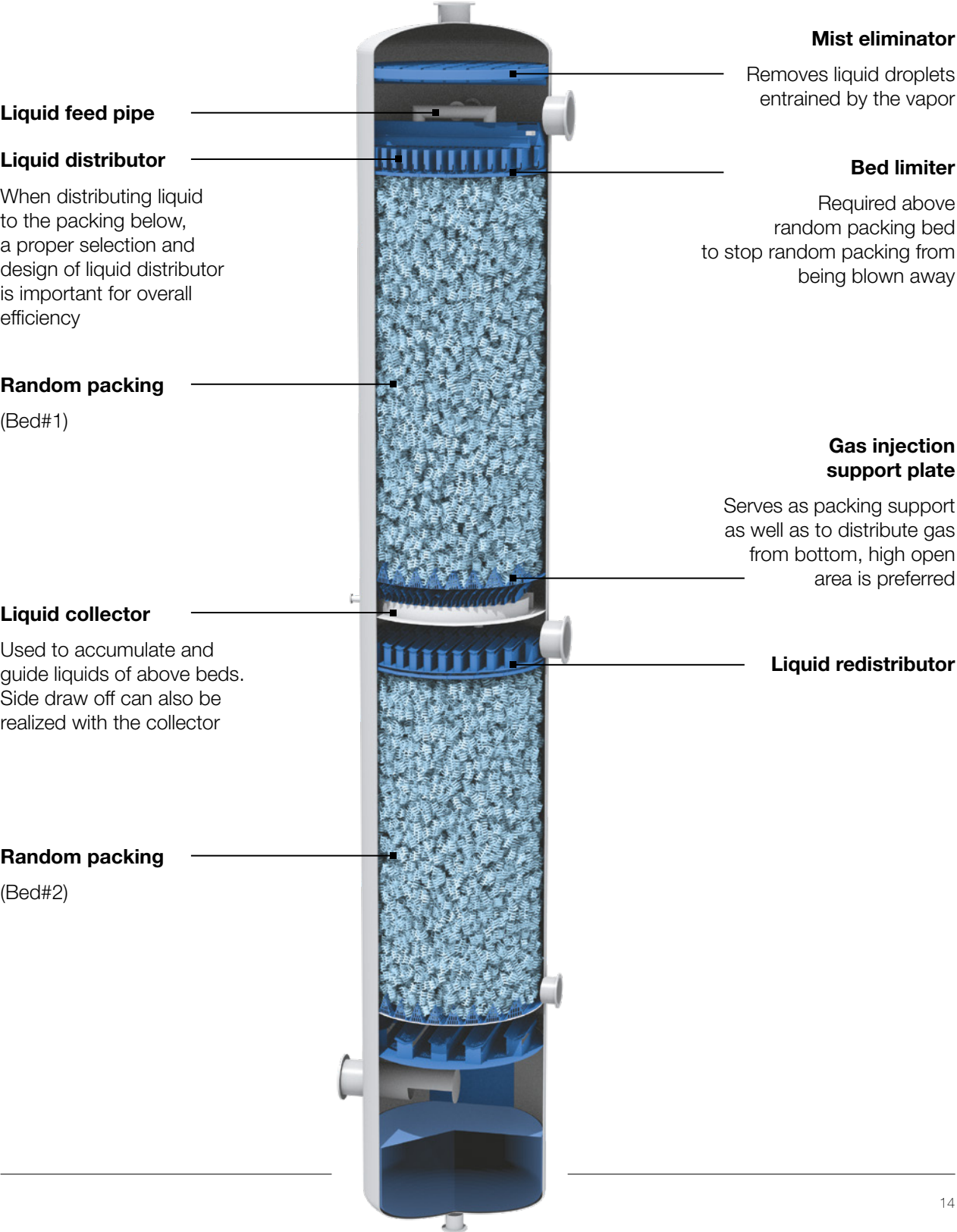

Comprehensive engineering services markets

Development and technology

Sulzer makes every effort to support our customers and continuously improve our design tools. Engineers in the R&D lab develop new and improved products, analyze and optimize processes.

We maintain close relationships to universities and independent research organizations to support these efforts.



Engineering and manufacturing

Sulzer has a long-standing manufacturing tradition. Sulzer owns dedicated factories in every region to produce mixers, columns, reactors, and heat exchangers.

For certain sizes and certain countries, we work with well-known and proven subcontractors who are bound by Sulzer manufacturing policies and quality standards.

Capabilities

Manufacturing according to PED 97/23/EC, ASME VIII Div.1, and ASME B31.3/U-Stamp, Gost (TR), China Stamp, Norsok, or NACE

Design codes acc. to AD2000, EN 13445, ASME Broad selection of material for construction available

Non-destructive testing (LPT, X-ray, pressure testing up to 500 bar, PMI, MT, UT etc. acc. EN and ASME)

Designing with SolidWorks

Strength calculations, FEM analysis, nozzle loads etc.

Certification for ISO 9001, ISO 14001 and ISO 18001

Experienced project management team

CFD Analysis

CFD calculations done in advance of fabrication can support the decision to go for a particular technology, and can save on the time required for commissioning and testing later. Sulzer uses CFD technology both for the modeling of existing and the development of new products.

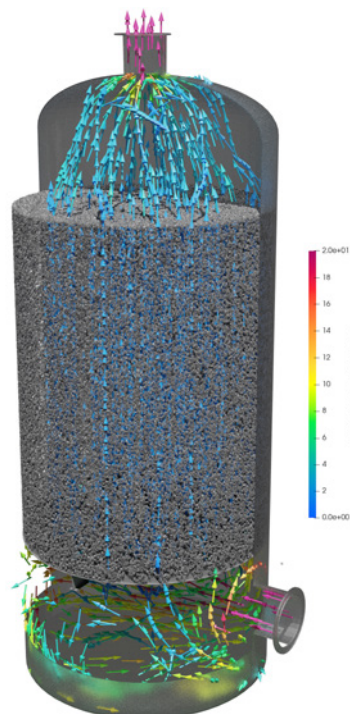

The Chemtech division is the global market leader in innovative mass transfer, static mixing and polymer solutions for petrochemicals, refining and LNG.

Chemtech is also leading the way in ecological solutions such as biopolymers as well as textile and plastic recycling, contributing to a circular economy. Our product offering ranges from technology licensing to process components all the way to complete separation process plants. Customer support ranges from engineering and field services to tray and packing installation, tower maintenance, welding and plant turnaround projects – ensuring minimal downtime.

E10534 en 6.2024, Copyright © Sulzer Ltd 2024

This brochure is a general presentation. It does not provide any warranty or guarantee of any kind. Please, contact us for a description of the warranties and guarantees offered with our products. Directions for use and safety will be given separately. All information herein is subject to change without notice.

