

Mechanical seals and accessories

TB1, TB1F and TB2P ready-fitted mechanical seals for AHLSTAR pumps

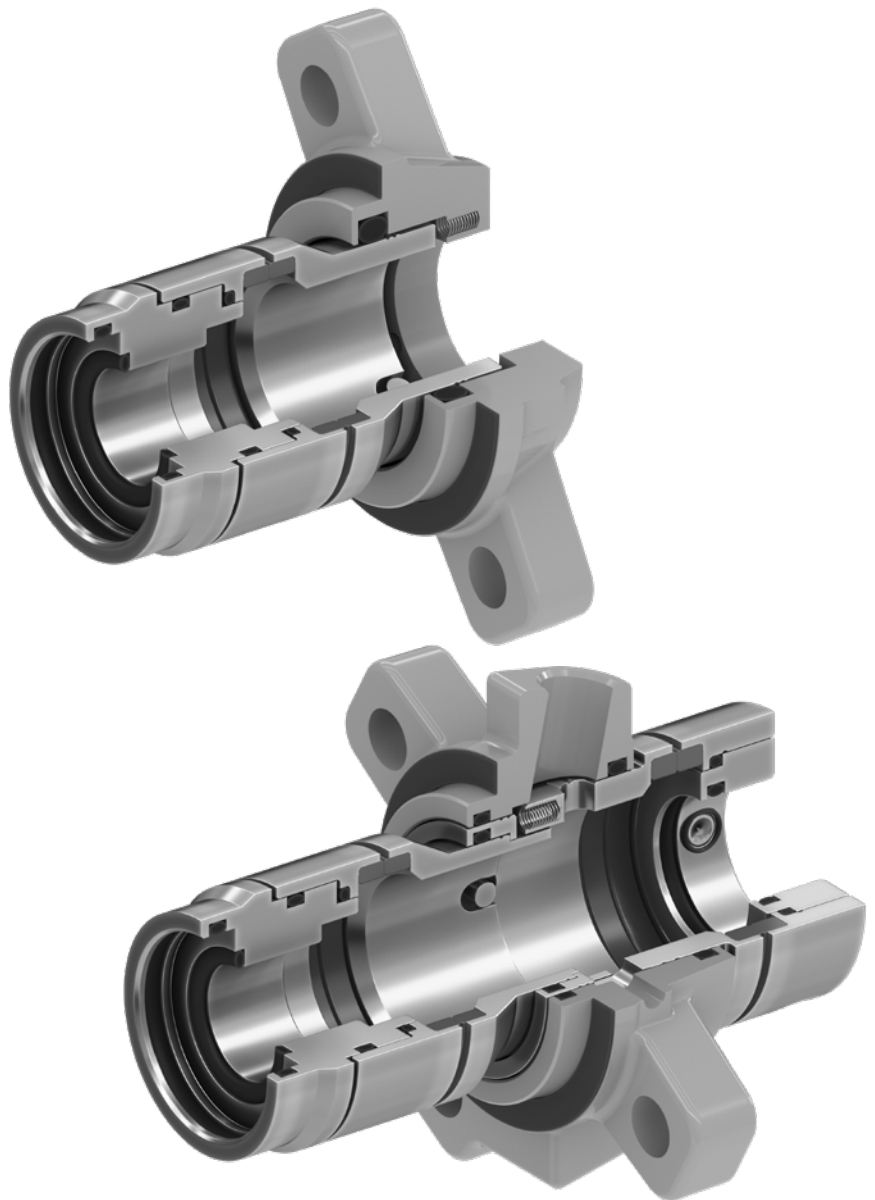

Ready-fitted mechanical seals for enhanced pump reliability

TB1, TB1F, and TB2P ready-fitted mechanical seals have been specifically designed to fit seamlessly into the seal chamber of standard gland packing casing covers and to work with standard shafts without the need for additional shaft sleeves. These seals are suitable for various pump types, including AHLSTAR process pump range models A, APP, NPP, and WPP.

These ready-fitted seals are designed to be an integral part of certain centrifugal pump types, eliminating the need for extra components and maximizing the space between the seal and casing cover, thus enhancing reliability.

Fast and easy installation and robust design

Installation is easy; these seals can be securely connected directly to the pump. There's no need for additional components like shaft sleeves, which results in an optimal material wall thickness, ensuring highly reliable operation.

These ready-fitted seals are simple and robust, allowing fast and easy installation and maintenance without the need for complex setting clips, which are required with cartridge seals.

Versatile sealing solutions for optimal performance and cost efficiency

There are two seal solutions available: the single seal is engineered to withstand pressure variations and dropouts of the pumped liquid without opening the seal faces.

The double seal, on the other hand, is designed to handle pressure changes on both the pumped and sealing liquids, as well as vacuum pressure, without opening the seal faces. The double seal is designed for closed circulation sealing liquid systems and can pump sealing liquid on its own, eliminating the need for a separate circulation pump.

The seal faces are precisely aligned with the shaft, thanks to flexible O-rings, ensuring a long and reliable operation. This, combined with their straightforward design, makes these seals significantly more cost-effective than cartridge mechanical seals.



Technical specifications and material alternatives

	TB1	TB1F	TB2P
P_{max}	25 bar / 362 psi	25 bar / 362 psi	25 bar / 362 psi
V_{max}	25 m/s / 82 ft/s	25 m/s / 82 ft/s	25 m/s / 82 ft/s
T_{max}	125°C / 257°F	140°C / 284°F with internal flushing or external flushing	180°C / 355°F
Seal faces	SiC/SiC, C/SiC	SiC/SiC, C/SiC	SiC/SiC-SiC/SiC SiC/SiC-C/SiC
O-rings	EPDM, FKM		
Wetted parts	316 stainless steel (EN 1.4401, EN 1.4436), duplex EN 1.4462, super duplex EN 1.4410		

TB1 ready-fitted single mechanical seal

The seal faces are lubricated by the pumped liquid pumped through the impeller balancing holes into the seal chamber

- Positive inlet pressure is required
- Impeller balancing holes are required

Liquids

- Clean and slightly contaminated liquids
- Viscous liquids
- Fibrous slurries up to 2% depending on quality
- Temperature up to 125°C / 257°F

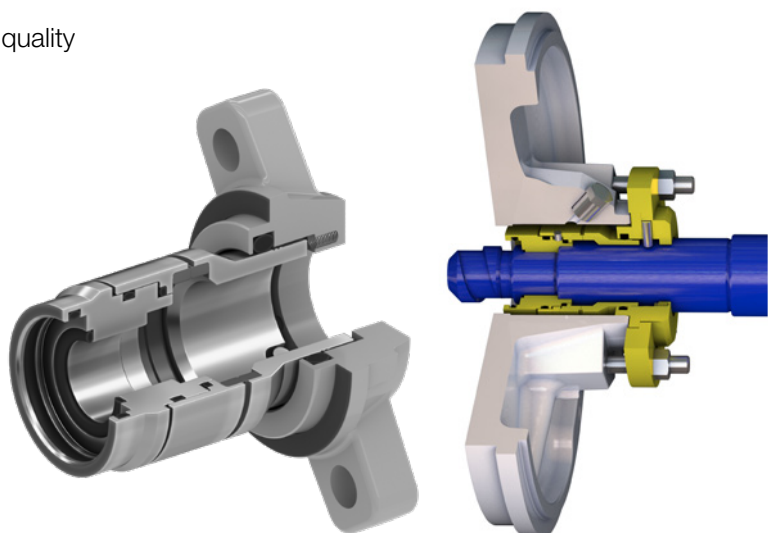

TB1F ready-fitted single mechanical seal with flushing

Internal recirculation liquids

The seal faces are lubricated by the pumped liquid which is circulated through a pipe from the discharge pipe into the seal chamber

- Positive or negative inlet pressure
- Impeller balancing holes are not required, but can be

Liquids

- Clean and slightly contaminated liquids
- Viscous liquids up to 250 cSt
- Temperature up to 120°C / 248°F depending on seal chamber pressure

External flush liquids

The seal faces are lubricated by external clean flushing liquid led through a pipe from an external source into the seal chamber

- Positive or negative inlet pressure
- Impeller balancing holes are not required, but can be

Liquids

- Clean and slightly contaminated liquids
- Viscous liquids up to 4'000 cSt
- Fibrous slurries up to 8%
- Non-fibrous slurries up to 70%
- Liquids containing large solids
- Temperature up to 140°C / 284°F

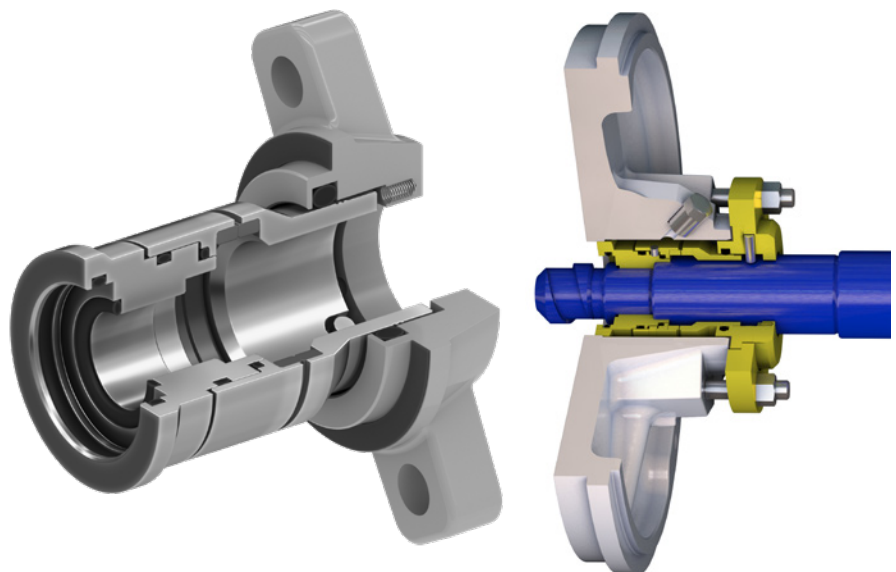

TB2P ready-fitted double mechanical seal

The seal faces are lubricated by non-pressurized (buffer) or pressurized (barrier) external clean sealing liquid led through a pipe/hose from an external source into the seal between the seal face pairs

- Positive or negative inlet pressure
- Impeller balancing holes are not required, but can be

Temperature of the out-flowing sealing liquid may not exceed 60°C / 140°F

Liquids

- Clean and slightly contaminated liquids
- Viscous liquids up to 4'000 cSt
- Fibrous slurries up to 8%
- Liquids containing large solids
- Temperature up to 180°C / 355°F

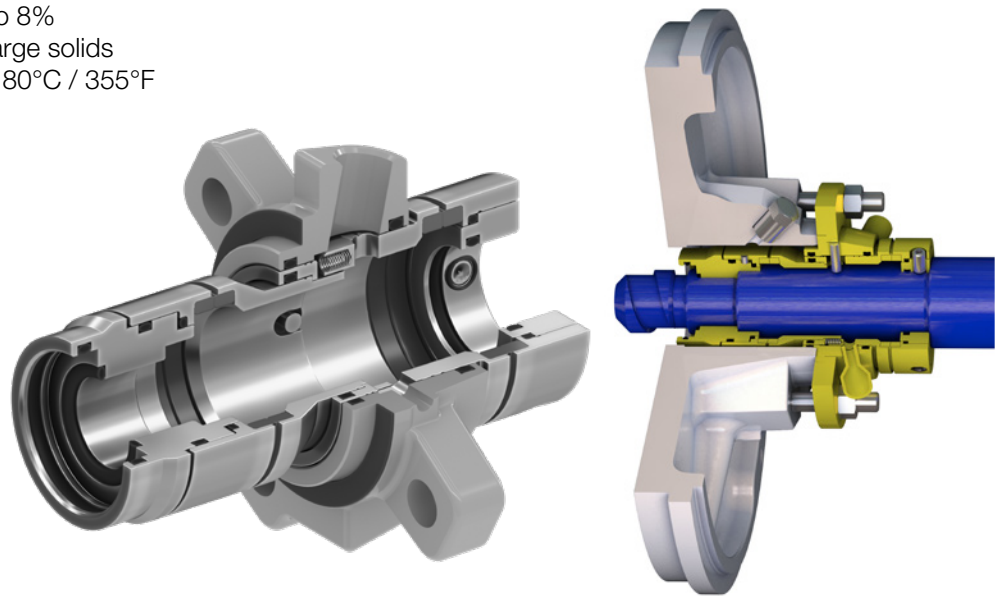

The Sulzer Flow division keeps your processes flowing. Wherever fluids are treated, pumped, or mixed, we deliver highly innovative and reliable solutions for the most demanding applications.

The Flow division specializes in pumping solutions specifically engineered for the processes of our customers. We provide pumps, agitators, compressors, grinders, screens and filters developed through intensive research and development in fluid dynamics and advanced materials. We are a market leader in pumping solutions for water, oil and gas, power, chemicals and most industrial segments.

E10240 en 9.2024, Copyright © Sulzer Ltd 2024

This brochure is a general presentation. It does not provide any warranty or guarantee of any kind. Please, contact us for a description of the warranties and guarantees offered with our products. Directions for use and safety will be given separately. All information herein is subject to change without notice.

