

---

**Submersible Recirculation Pump Type ABS XRCP 250 - 800 PA**

---

2508-0000

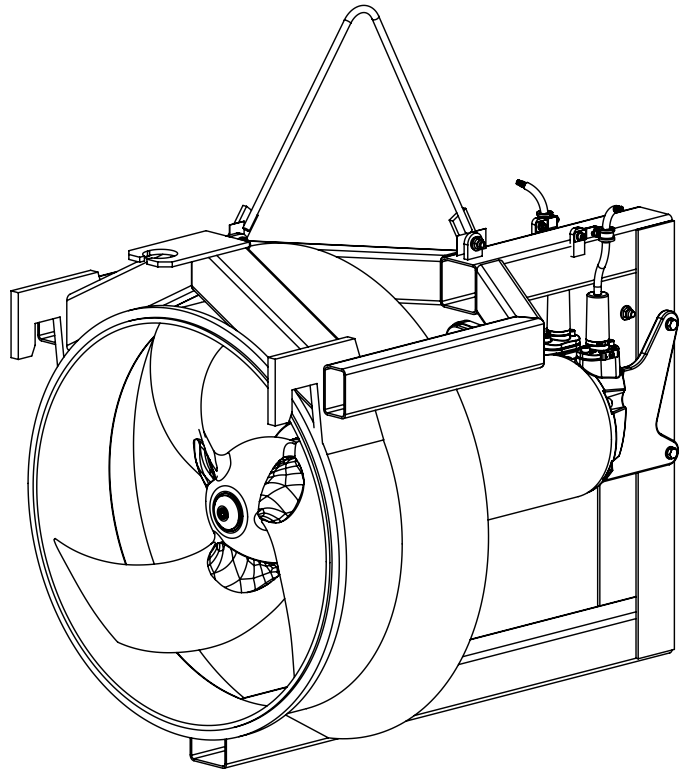
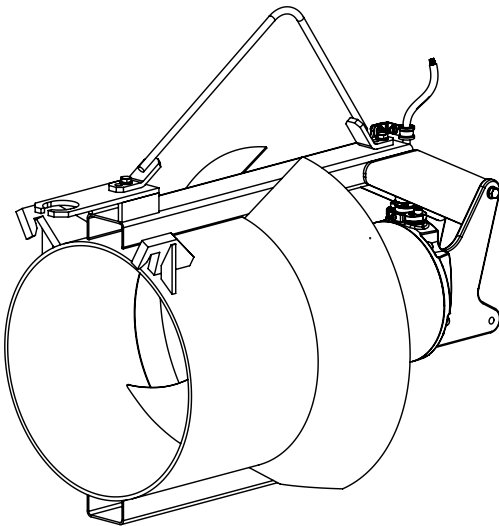
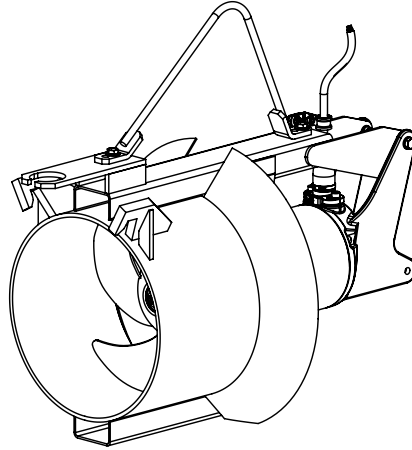
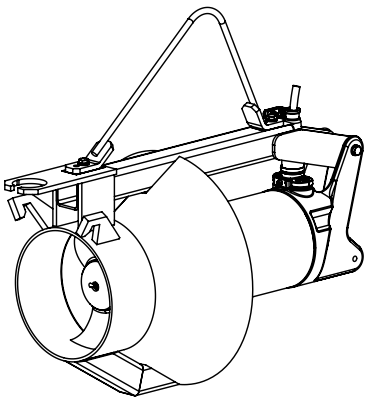

6006619-05 (07.2023)

en

Installation and operating instructions

# Installation and operating instructions (Translation of original instructions)

Submersible recirculation pump type ABS XRCP

XRCP 250

XRCP 400

XRCP 500

XRCP 800 PA

## Table of contents

<b>1</b>	<b>General</b> .....	<b>4</b>
1.1	Introduction .....	4
1.2	Correct usage of the products.....	4
1.3	Application restrictions of XRCP .....	4
1.4	Application areas .....	5
1.4.1	Application areas XRCP.....	5
1.5	Identification code .....	6
1.6	Technical data .....	7
1.6.1	Technical data 50 Hz.....	7
1.6.2	Technical data 60 Hz.....	8
1.7	Dimensions and weights .....	9
1.7.1	Dimensions XRCP 250 .....	9
1.7.2	Dimensions XRCP 400/500 .....	9
1.7.3	Dimensions XRCP 800 PA.....	10
1.7.4	Flange dimension check .....	10
1.8	Nameplate.....	11
<b>2</b>	<b>Safety</b> .....	<b>12</b>
2.1	General .....	12
2.2	Safety instructions for permanent magnet motors .....	12
<b>3</b>	<b>Transport and storage</b> .....	<b>13</b>
3.1	Transport.....	13
3.2	Lifting.....	13
3.3	Motor connection cable moisture protection .....	13
3.4	Storage of the units.....	14
<b>4</b>	<b>Product description</b> .....	<b>14</b>
4.1	General description .....	14
4.2	Motor description.....	14
<b>5</b>	<b>Structural design</b> .....	<b>15</b>
5.1	XRCP 250/400/500 .....	15
5.2	XRCP 800 PA.....	15

Sulzer reserves the right to alter specifications due to technical developments !

<b>6</b>	<b>Installation .....</b>	<b>16</b>
6.1	Installation general .....	16
6.2	Disassembling/assembling the propeller.....	16
6.2.1	Propeller disassembly / assembly, XRCP 250/400/500 .....	16
6.2.2	Propeller disassembly, XRCP 250/400/500 .....	17
6.2.3	Propeller disassembly / assembly, XRCP 800 PA.....	17
6.2.4	Propeller disassembly, XRCP 800 PA.....	18
6.2.5	Propeller assembly, XRCP 250/400/500 .....	19
6.2.6	Propeller assembly, XRCP 800 PA.....	19
6.3	Tightening torque .....	19
6.4	Fitting position of the Nord-Lock® securing washers.....	19
6.5	Installation example with ABS lifting unit.....	20
6.6	Guide tube installation.....	21
6.7	Securing and positioning of the motor connection cables of the XRCP .....	22
6.8	Lowering of the XRCP along the guide tube .....	23
<b>7</b>	<b>Electrical connection .....</b>	<b>24</b>
7.1	Connection diagram VFD (only for XRCP 400, XRCP 500).....	25
7.2	Standard connection diagrams - mains voltage 380 - 420 V at 50 Hz / 460 V at 60 Hz .....	26
7.2.1	Standard connection diagram XRCP 250 .....	26
7.2.2	Standard connection diagram XRCP 800 PA.....	26
7.3	Lead designations .....	27
7.4	Motor monitoring .....	27
7.5	Connection of the seal monitoring unit to the control panel .....	28
7.6	Operation with frequency inverters (for XRCP 250 and XRCP 800 PA) .....	29
7.7	Soft starter (Option).....	30
<b>8</b>	<b>Direction of rotation.....</b>	<b>31</b>
8.1	Checking direction of rotation .....	31
8.2	Changing direction of rotation .....	32
<b>9</b>	<b>Commissioning .....</b>	<b>32</b>
<b>10</b>	<b>Maintenance .....</b>	<b>33</b>
10.1	General maintenance hints .....	33
10.2	Maintenance XRCP.....	33
10.3	Faults .....	34
10.4	Inspection and maintenance intervals for XRCP .....	34

# 1 General

## 1.1 Introduction

These **Installation and Operating Instructions** and the separate booklet **Safety Instructions for Sulzer Products Type ABS** contain basic instructions and safety hints which must be observed during transport, installation and commissioning. For this reason it is essential that they are read by the installing technician as well as by relevant skilled operators or users. They should also be always available where the unit is installed.



Safety instructions which might cause danger to life in case of non-observance have been specifically highlighted with the general danger symbol.



The presence of a dangerous voltage is identified with this safety symbol.



This symbol indicates the danger of an explosion occurring.

**ATTENTION** *Appears at safety hints, the non-observance of which could damage the unit or affect its functioning.*

**NOTE** *Used for important pieces of information.*

Illustrations code; e.g. (3/2). The first digit refers to the figure no. and the second digit to the position in that figure.

## 1.2 Correct usage of the products

The Sulzer products have been designed and built in accordance with the latest technology and taking into account the relevant safety regulations. However improper usage could cause a danger to life or limb of the user or a third party, or cause damage or function impairment to the unit itself and other items of value.

The Sulzer units should only be used if they are in perfect technical condition, taking into account all safety requirements, and conscious of the need to avoid potential dangers. The contents of the installation and operating instructions and the safety hints must be applied! Any other usage (abnormal usage) or usage beyond that specified will be considered as non-compliance. The manufacturer/supplier will not accept any responsibility for damage due to this. The risk is borne by the user. In case of doubt the entire scope of the planned application must be approved by **Sulzer Pump Solutions Ireland Ltd** (in the following called Sulzer).

In the case of any faults arising, the Sulzer units should immediately be taken out of use and secured. The fault should be immediately rectified, or if necessary, contact your Sulzer Service Centre.

## 1.3 Application restrictions of XRCP

The XRCP can be supplied both as standard versions and in explosion-proof execution (ATEX II 2G Ex h db IIB T4 Gb) for 50 Hz according to the standards EN 60079-0:2012 + A11:2018, EN 60079-1: 2014, EN ISO 80079-36, EN ISO 80079-37, EN ISO 12100:2010, EN 809:1998 + A1:2009 + AC:2010, EN 61000-6-1:2019, EN 61000-6-2:2019, EN 61000-6-3:2007, EN 61000-6-4:2007, or FM (NEC 500. Class I, Division 1. Group C&D. T3C) approval for 60 Hz.

**Limitations:** The ambient temperature range is 0 °C to + 40 °C (32 °F to 104 °F)  
Immersion depth maximum 20 m (65 ft)

**ATTENTION** *If cable length is less than 20 m (65 ft) the max. immersion depth reduces accordingly. In special cases an immersion depth greater than 20 m (65 ft) is possible. However, the maximum number of starts according to the motor datasheet may not be exceeded. In order to do this you need the written approval from the manufacturer Sulzer.*



Pumping of flammable or explosive liquids with these pumps is not allowed!



Only explosion-proof executions may be used in hazardous areas!

### **For the operation of Ex-XRCP:**

In hazardous areas care must be taken that during switching on and operation of the unit it is submerged or under water. Other types of operation e.g. snore operation or dry running are not allowed!

It must be ensured that the motor of the Ex-XRCP is always fully submerged during start-up and operation!

The temperature monitoring of the Ex-XRCP has to be carried out by bimetallic temperature limiters or thermistors according to DIN 44 082 connected to a suitable release device which is certified in accordance with EC directive 2014/34/EU.

**ATTENTION**      ***XRCP with Ex h db IIB T4 approval are not equipped with a leakage sensor (DI) in the oil chamber.***

**ATTENTION**      ***XRCP 250/400/500 with FM approval (NEC 500) can be equipped (as an option) with a leakage sensor (DI) in the oil chamber. Due to the design this is not possible in XRCP 800 PA.***

**NOTE**              ***Ex protection methods type “c” (constructional safety) and type “k” (liquid immersion) in accordance with EN ISO 80079-36 and EN ISO 80079-37 are used.***

### **For the operation of Ex-XRCP with frequency inverter in hazardous areas (ATEX Zone 1 and 2):**

Motors must have direct thermal protection devices fitted. These consist of temperature sensors (PTC DIN 44 082) embedded in the windings. These must be connected to a suitable release device which is certified in accordance with EC directive 2014/34/EU.

Machines designated as Ex machines may never, without exception, be operated using a mains frequency that is greater than the maximum of 50 Hz or 60 Hz as indicated on the nameplate.

**ATTENTION**      ***Repair work on explosion-proof motors may only be carried out in authorized workshops by qualified personnel using original parts supplied by the manufacturer. Otherwise the Ex approvals are no longer valid. All Ex-relevant components and dimensions can be found in the modular workshop manual and the spare parts list.***

**ATTENTION**      ***After repair work in unauthorized workshops by unqualified personnel the Ex approvals are no longer valid. After such repair the unit must not be operated in hazardous areas and the Ex nameplate (see figure 5b, 5c) has to be removed.***

## **1.4 Application areas**

### **1.4.1 Application areas XRCP**

The submersible recirculation pumps type ABS XRCP 250 - 800 PA are fitted with water-pressure-tight encapsulated motors and are quality products suitable for use in the following areas:

- Pumping and recirculation of active sludge in treatment plants with nitrogen removal (nitrification/denitrification).
- Pumping of rain and surface water.

**ATTENTION**      ***Leakage of lubricants could result in pollution of the medium being pumped.***

## 1.5 Identification code

Hydraulics

Motor

**XRCP 40 3 1 A PM 30 / 10- 3 Ex CR**

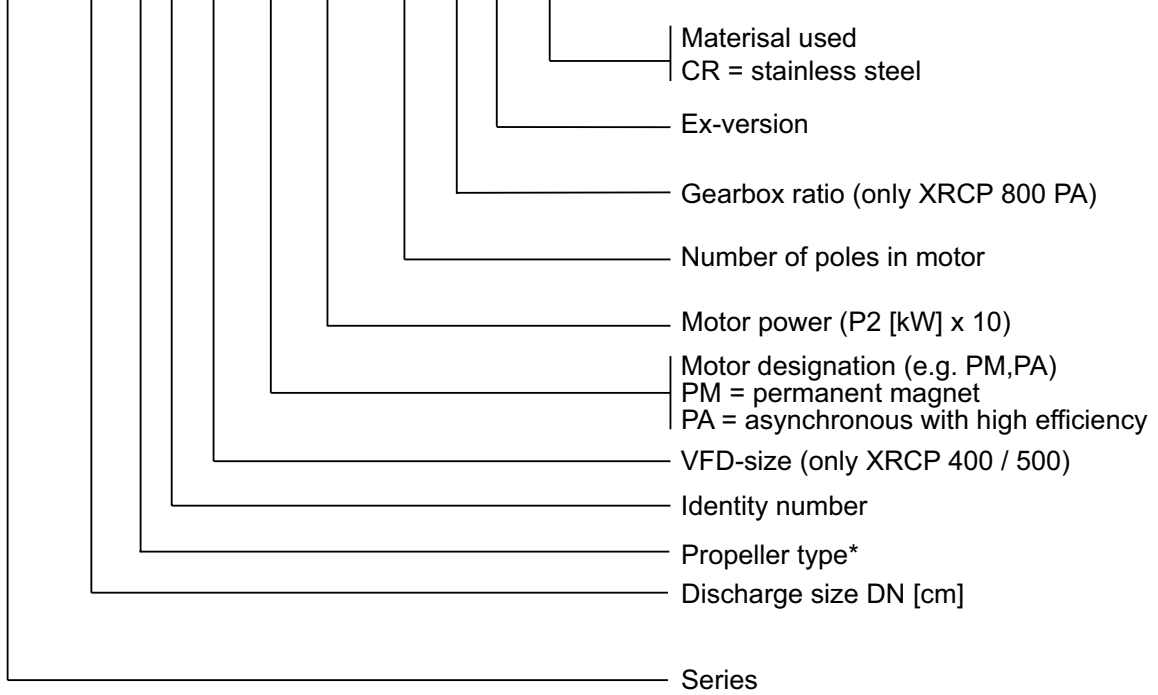

\*Propeller type: 1 = Mixing propeller (only without flow ring); 2 = 2-blade thrust propeller; 3 = 3-blade thrust propeller; 4 = 2-blade thrust propeller with flow ring; 5 = 3-blade thrust propeller with flow ring; 7 = 3-blade special propeller for biofilm carrier process

*Identification code XRCP*

## 1.6 Technical data

The maximum noise level of the units of this series is  $\leq 70$  dB(A). In some types of installation it is possible that the noise level of 70 dB(A) or the measured noise level will be exceeded.

### 1.6.1 Technical data 50 Hz

Hydraulics type	Propeller diameter	Propeller speed	$H_{max}$	$Q_{max}$	Motor type	Rated input power $P_1$	Rated motor power $P_2$	Starting: Direct (D.O.L)	Starting: Star/Delta	Rated current at 400 V or maximum current VFD	Starting current at 400 V	Cable type**	Total weight
	[mm]	[1/min]	[m]	[l/s]		[kW]	[kW]			[A]	[A]		[kg]
2521	247	958	0.9	95	PA 15/ 6	1.9	1.5	●	-	3.5	37.3	1	85
2531	247	958	1.0	115	PA 15/ 6	1.9	1.5	●	-	3.5	37.3	1	85
2532	247	958	1.5	125	PA 15/ 6	1.9	1.5	●	-	3.5	37.3	1	85
2533	247	971	1.8	150	PA 29/ 6	3.4	2.9	●	-	7.3	49.0	1	107
4031A	394	525	1.1	50	PM 30/10	3.4	3.0	●*	-	9.9	9.9	1	145
4032A	394	550	1.1	60	PM 30/10	3.4	3.0	●*	-	9.9	9.9	1	145
4033A	394	575	1.1	75	PM 30/10	3.4	3.0	●*	-	9.9	9.9	1	145
4034A	394	600	1.25	75	PM 30/10	3.4	3.0	●*	-	9.9	9.9	1	145
4035A	394	625	1.3	80	PM 30/10	3.4	3.0	●*	-	9.9	9.9	1	145
4031B	394	650	1.4	90	PM 50/10	5.8	5.0	●*	-	12.9	12.9	1	145
4032B	394	675	1.4	100	PM 50/10	5.8	5.0	●*	-	12.9	12.9	1	145
4033B	394	700	1.4	130	PM 50/10	5.8	5.0	●*	-	12.9	12.9	1	145
4034B	394	725	1.5	180	PM 50/10	5.8	5.0	●*	-	12.9	12.9	1	145
4035B	394	750	1.3	225	PM 50/10	5.8	5.0	●*	-	12.9	12.9	1	145
5031A	492	300	1.0	370	PM 55/24	6.1	5.5	●*	-	12.9	12.9	1	200
5032A	492	325	1.05	410	PM 55/24	6.1	5.5	●*	-	12.9	12.9	1	200
5033A	492	350	1.1	440	PM 55/24	6.1	5.5	●*	-	12.9	12.9	1	200
5031B	492	375	1.1	480	PM 75/24	8.3	7.5	●*	-	15.8	15.8	1	200
5032B	492	400	1.1	500	PM 75/24	8.3	7.5	●*	-	15.8	15.8	1	200
5033B	492	425	1.1	530	PM 75/24	8.3	7.5	●*	-	15.8	15.8	1	200
5031C	492	450	1.15	580	PM 100/24	11.0	10.0	●*	-	24.2	24.2	2	200
5032C	492	475	1.15	620	PM 100/24	11.0	10.0	●*	-	24.2	24.2	2	200
5033C	492	500	1.0	650	PM 100/24	11.0	10.0	●*	-	24.2	24.2	2	200
8031 PA	792	296 <sup>1</sup>	1.13	1179	PA 110/4	11.9	11.0	-	●	21.7	181.0	3	405
8032 PA	792	296 <sup>1</sup>	1.08	1257	PA 150/4	16.3	15.0	-	●	29.9	259.0	2	407
8031 PA	792	370 <sup>2</sup>	1.63	1464	PA 220/4	23.9	22.0	-	●	44.8	376.0	4	428
8032 PA	792	370 <sup>2</sup>	1.50	1581	PA 220/4	23.9	22.0	-	●	44.8	376.0	4	428
8033 PA	792	370 <sup>2</sup>	1.31	1680	PA 250/4	27.4	25.0	-	●	50.9	376.0	4	428

\*Starting: Variable frequency drive (VFD)

\*\*Cable type: 10 m cable with free cable ends as standard: 1 = 1 x 7G1.5; 2 = 1 x 10G 2.5; 3 = 1 x 10G1.5; 4 = 2 x 4G4+2 x 0.75

<sup>1</sup> Propeller speed with gear ratio i=5

<sup>2</sup> Propeller speed with gear ratio i=4

### 1.6.2 Technical data 60 Hz

Hydraulics type	Propeller diameter	Propeller speed	H <sub>max</sub>	Q <sub>max</sub>	Motor type	Rated input power P <sub>1</sub>	Rated motor power P <sub>2</sub>	Starting: Direct (D.O.L)	Starting: Star/Delta	Rated current at 480 V or maximum current VFD	Starting current at 480 V	Cable type**	Total weight
	[mm]	[1/min]	[m]	[l/s]		[kW/hp]	[kW/hp]			[A]	[A]		[kg/lbs]
2521	247	1153	1.1	105	PA 18/ 6	2.2 / 2.9	1.8 / 2.4	●	-	3.5	22.2	1	85 / 187
2531	247	1153	1.5	145	PA 18/ 6	2.2 / 2.9	1.8 / 2.4	●	-	3.5	22.2	1	85 / 187
2531	247	1169	1.5	145	PA 35/6	4.1 / 5.5	3.5 / 4.7	●	-	6.9	53.9	1	107 / 236
2532	247	1169	2.0	150	PA 35/ 6	4.1 / 5.5	3.5 / 4.7	●	-	6.9	53.9	1	107 / 236
2533	247	1169	2.4	175	PA 35/ 6	4.1 / 5.5	3.5 / 4.7	●	-	6.9	53.9	1	107 / 236
4031A	394	525	1.1	50	PM 30/10	3.4 / 4.6	3.0 / 4.0	●*	-	8.1	8.1	1	145 / 320
4032A	394	550	1.1	60	PM 30/10	3.4 / 4.6	3.0 / 4.0	●*	-	8.1	8.1	1	145 / 320
4033A	394	575	1.1	75	PM 30/10	3.4 / 4.6	3.0 / 4.0	●*	-	8.1	8.1	1	145 / 320
4034A	394	600	1.25	75	PM 30/10	3.4 / 4.6	3.0 / 4.0	●*	-	8.1	8.1	1	145 / 320
4035A	394	625	1.3	80	PM 30/10	3.4 / 4.6	3.0 / 4.0	●*	-	8.1	8.1	1	145 / 320
4031B	394	650	1.4	90	PM 50/10	5.8 / 7.7	5.0 / 6.7	●*	-	10.9	10.9	1	145 / 320
4032B	394	675	1.4	100	PM 50/10	5.8 / 7.7	5.0 / 6.7	●*	-	10.9	10.9	1	145 / 320
4033B	394	700	1.4	130	PM 50/10	5.8 / 7.7	5.0 / 6.7	●*	-	10.9	10.9	1	145 / 320
4034B	394	725	1.5	180	PM 50/10	5.8 / 7.7	5.0 / 6.7	●*	-	10.9	10.9	1	145 / 320
4035B	394	750	1.3	225	PM 50/10	5.8 / 7.7	5.0 / 6.7	●*	-	10.9	10.9	1	145 / 320
5031A	492	300	1.0	370	PM 55/24	6.1 / 8.2	5.5 / 7.4	●*	-	10.9	10.9	1	200 / 441
5032A	492	325	1.05	410	PM 55/24	6.1 / 8.2	5.5 / 7.4	●*	-	10.9	10.9	1	200 / 441
5033A	492	350	1.1	440	PM 55/24	6.1 / 8.2	5.5 / 7.4	●*	-	10.9	10.9	1	200 / 441
5031B	492	375	1.1	480	PM 75/24	8.3 / 11.1	7.5 / 10.0	●*	-	14.3	14.3	1	200 / 441
5032B	492	400	1.1	500	PM 75/24	8.3 / 11.1	7.5 / 10.0	●*	-	14.3	14.3	1	200 / 441
5033B	492	425	1.1	530	PM 75/24	8.3 / 11.1	7.5 / 10.0	●*	-	14.3	14.3	1	200 / 441
5031C	492	450	1.15	580	PM 100/24	11.0 / 14.8	10.0 / 13.4	●*	-	20.9	20.9	2	200 / 441
5032C	492	475	1.15	620	PM 100/24	11.0 / 14.8	10.0 / 13.4	●*	-	20.9	20.9	2	200 / 441
5033C	492	500	1.0	650	PM 100/24	11.0 / 14.8	10.0 / 13.4	●*	-	20.9	20.9	2	200 / 441
8031 PA	792	296 <sup>1</sup>	1.16	1163	PA 130/4	13.9 / 18.6	13.0 / 17.4	-	●	22.8	189.0	3	405 / 893
8032 PA	792	296 <sup>1</sup>	1.10	1288	PA 170/4	18.3 / 24.5	17.0 / 22.8	-	●	28.8	250.0	2	407 / 898
8031 PA	792	356 <sup>2</sup>	1.41	1394	PA 170/4	18.3 / 24.5	17.0 / 22.8	-	●	28.8	250.0	2	407 / 898
8032 PA	792	356 <sup>2</sup>	1.42	1513	PA 250/4	27.0 / 36.2	25.0 / 33.5	-	●	43.2	367.0	4	428 / 944
8033 PA	792	356 <sup>2</sup>	1.44	1621	PA 250/4	27.0 / 36.2	25.0 / 33.5	-	●	43.2	367.0	4	428 / 944

\*Starting: Variable frequency drive (VFD)

\*\*Cable type: 10 m cable with free cable ends as standard: 1 = 1 x 7G1.5; 2 = 1 x 10G 2.5; 3 = 1 x 10G1.5; 4 = 2 x 4G4+2 x 0.75

<sup>1</sup>Propeller speed with gear reduction i=6

<sup>2</sup>Propeller speed with gear reduction i=5



## 1.7 Dimensions and weights

**NOTE** The weights of the units can be obtained from the nameplate of the unit or from the table in section 1.6 Technical Data.

### 1.7.1 Dimensions XRCP 250

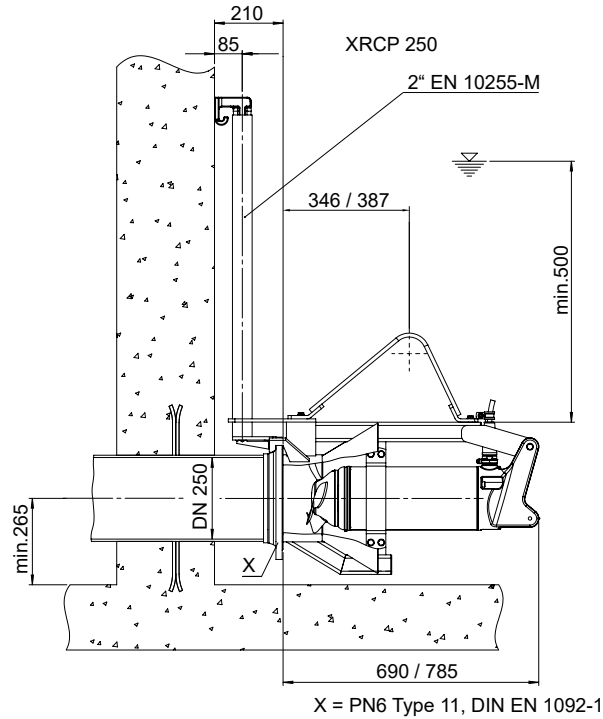
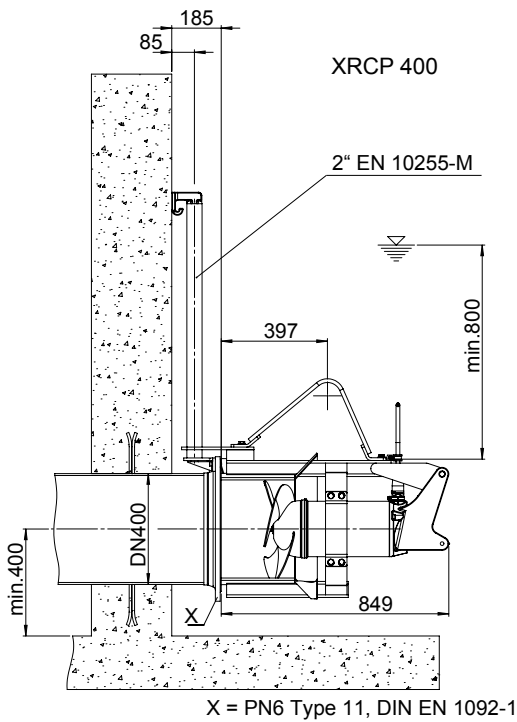
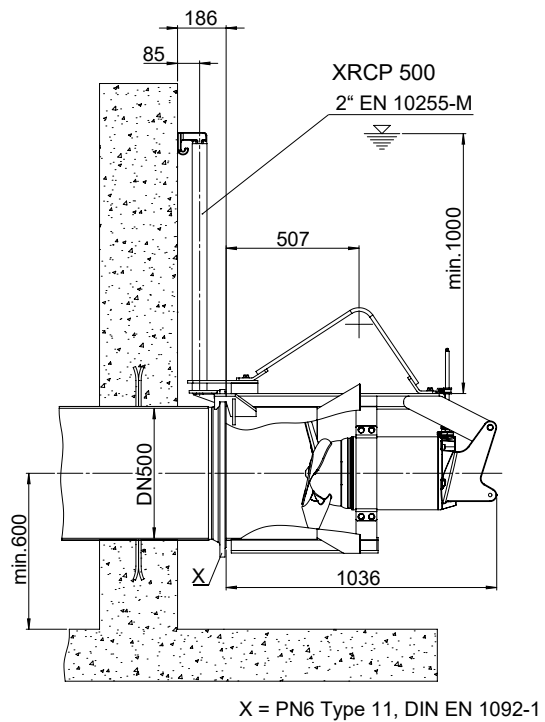

Figure 1 XRCP 250

### 1.7.2 Dimensions XRCP 400/500



2508-0002



2508-0003

Figure 2 XRCP 400 / XRCP 500

1.7.3 Dimensions XRCP 800 PA

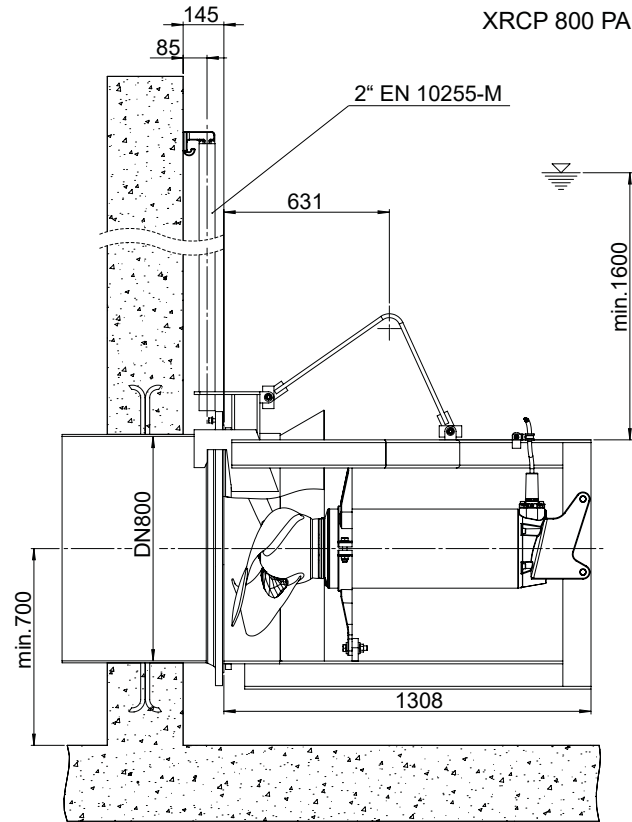

2508-0004

Figure 3 XRCP 800 PA

1.7.4 Flange dimension check

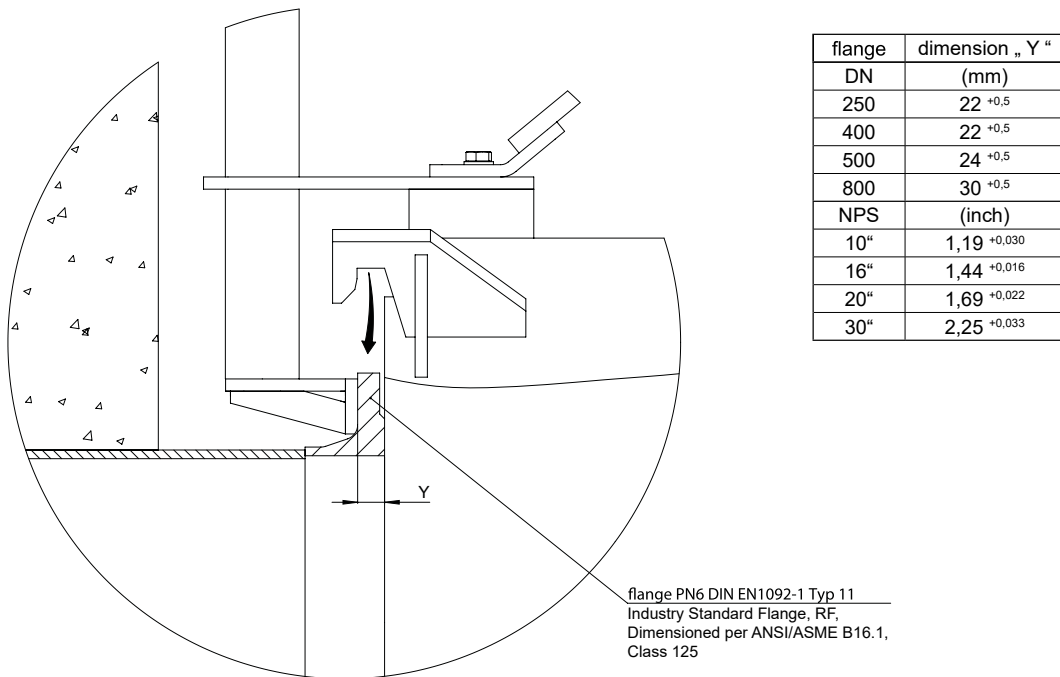

2508-0005

Figure 4 Flange dimensions

**ATTENTION** Before installing the recirculation pump, check the “Y” dimension of the flange. Make sure that the dimensions specified in the table are adhered to, otherwise the flange will need to be reworked.

## 1.8 Nameplate

We recommend that you record the data from the original nameplate *Figure 5a* so that you can refer to the data at any time.

SULZER		CE	
Type ②			⑤
PN ③		SN ④	⑥
U <sub>N</sub> ⑦ V	3~ ②⑦	max. ∇ ⑧	I <sub>N</sub> ⑨ A ⑩ Hz
P <sub>1N</sub> ⑪	P <sub>2N</sub> ⑫	n ⑬	∅ ⑭
T <sub>A</sub> max. ⑮ °C	Nema Code ⑯	Hmin. ⑰	
DN ⑱	Q ⑲	H ⑳	Hmax. ㉑
⑳	Weight ㉒	IP68 ㉓	㉔
Motor Eff. Cl ㉕	← ㉖		
Sulzer Pump Solutions Ireland Ltd. Clonard Road, Wexford. Ireland. ①			

Figure 5a Nameplate

### Legend

- |   |  |
|---|--|
| 1 Address                               | 15 Max. ambient temperature [flexible unit]        |
| 2 Type designation                      | 16 Nema code letter (only at 60 Hz, e.g., H)       |
| 3 Art. no.                              | 17 Min. pumping height [flexible unit]             |
| 4 Serial number                         | 18 Nominal width [flexible unit]                   |
| 5 Order number                          | 19 Pumping quantity [flexible unit]                |
| 6 Year of manufacture [month/year]      | 20 Pumping height [flexible unit]                  |
| 7 Nominal voltage                       | 21 Max. pumping height [flexible height]           |
| 8 Max. immersion depth [flexible unit]  | 22 Weight (without attached parts) [flexible unit] |
| 9 Nominal current                       | 23 Motor efficiency class                          |
| 10 Frequency                            | 24 Motor shaft direction of rotation               |
| 11 Power (consumption) [flexible unit]  | 25 Continuous operating mode                       |
| 12 Power (output) [flexible unit]       | 26 Sound level                                     |
| 13 Rotation speed [flexible unit]       | 27 Phase connection                                |
| 14 Impeller/Propeller ∅ [flexible unit] | 28 Protection method                               |



Figure 5b Nameplate ATEX

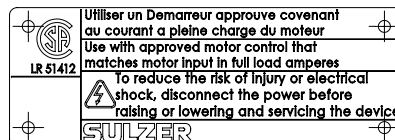
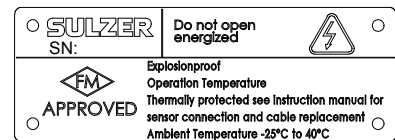

Figure 5c Nameplate CSA / FM



**NOTE** In all communication please state type of the unit, item and serial number.

**NOTE** Additional country-specific nameplates possible.

## 2 Safety

### 2.1 General

The general and specific health and safety hints are described in detail in the separate booklet **Safety Instructions for Sulzer Products Type ABS**. If anything is not clear or you have any questions as to safety make certain to contact the manufacturer Sulzer.



During assembly or maintenance, pay attention to the safety instructions in the manual for the frequency converter (FC)! All poles of the entire motor output must be disconnected from the mains supply. Adhere to the prescribed waiting times for complete discharge of the intermediate circuit. The “Safety stop” function is not activated.



The cable cross-section of the protective earth conductor (PE) to terminal 95 of the FC must be at least 10 mm<sup>2</sup> otherwise two separate ground cables must be used.



#### **Residual current circuit breaker (FI / RCD):**

The leakage current of the FC is > 3.5 mA. Only type “B” RCD devices (sensitive to universal current) may be used on the mains side.

#### **Short circuit protection:**

The FC must be protected against short circuit on the mains side in order to avoid electrical or fire risks. The FC output is completely protected against short circuit.



In order to comply with the EMC guidelines, shielded motor cables (up to 50 m category C1 cables according to EN 61800-3) are strongly recommended. When connecting, avoid twisting the shielding ends (pigtailes). The shielding connection should have the largest possible contact area. Interruptions should be continued with the lowest possible HF impedance.



Before maintenance work on the FC, the agitator must be disconnected. This prevents voltage from being induced by the rotating propellers in the flowing medium.

### 2.2 Safety instructions for permanent magnet motors

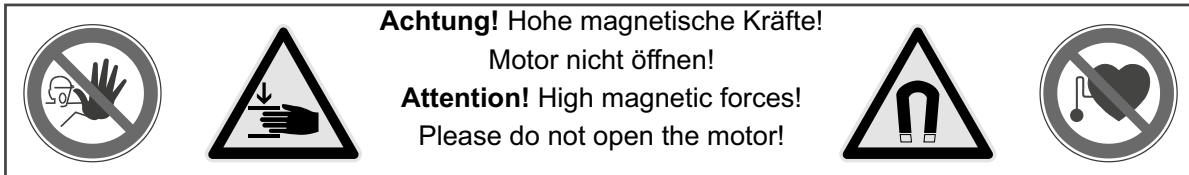

2508-0006



People with heart pacemakers should not position themselves in the proximity of strong magnets. If a neodymium magnet is located within 30 mm of a heart pacemaker it will stop working!



Do not use magnets if you are pregnant!



Do not use magnets if you wear an insulin pump.



Modern permanent magnets can attract steel objects or other magnets over large distances and cause concussion injuries or damage. Place non-ferrous objects (wood / polystyrene / plastic / aluminium) between magnets and any steel or other magnets to prevent this hazard.



Most magnets are brittle and may shatter if they hit each other or fall onto a steel surface. Always wear eye protection if this could happen.



Strong magnets may affect or interfere with sensitive electronic instruments and can destroy information stored on magnetic media such as credit cards, floppy discs and computer hard drives. Always keep magnets at a distance of at least 1 m from such devices.



Analogue watches and computer monitors can be permanently damaged if they are located in the proximity of magnets

### 3 Transport and storage

#### 3.1 Transport



The unit must never be raised by the power cable.

The units are fitted with a lifting hoop to which a wire rope can be fastened by means of shackles for transportation, installation or removal.



Take note of the entire weight of the unit (*see nameplate Figure 5*). The hoist and wire rope must be adequately dimensioned for the weight of the unit and must comply with the current valid safety regulations as well as good technical practice.



The unit should be protected from rolling over!



The unit is prepared for transportation by placing it on an adequately strong, completely horizontal surface, taking care that it cannot topple over.



Do not stay or work in the swivel area of a suspended load!



The lifting hook height must take into consideration the entire height of the unit as well as the length of the wire rope.

#### 3.2 Lifting

**ATTENTION** *Observe the total weight of the Sulzer units and their attached components (see nameplate for weight of base unit).*

The duplicate nameplate provided must always be located and visible close to where the pump is installed (e.g. at the terminal boxes/control panel where the pump cables are connected).

**NOTE** *Lifting equipment must be used if the total unit weight and attached accessories exceeds local manual lifting safety regulations.*

The total weight of the unit and accessories must be observed when specifying the safe working load of any lifting equipment! The lifting equipment, e.g. crane and chains, must have adequate lifting capacity. The hoist must be adequately dimensioned for the total weight of the Sulzer units (including lifting chains or steel ropes, and all accessories which may be attached). The end user assumes sole responsibility that lifting equipment is certified, in good condition, and inspected regularly by a competent person at intervals in accordance with local regulations. Worn or damaged lifting equipment must not be used and must be properly disposed of. Lifting equipment must also comply with the local safety rules and regulations.

**NOTE** *The guidelines for the safe use of steel chains, ropes and shackles supplied by Sulzer are outlined in the Lifting Equipment manual provided with the items and must be fully adhered to.*

#### 3.3 Motor connection cable moisture protection

The motor connection cables are protected against the ingress of moisture along the cable by having the ends sealed at manufacture with protective covers.

**ATTENTION** *These protective covers should only be removed immediately prior to connecting the pumps electrically.*

Prior to laying and connection of the power cable of the motor, particular attention is necessary during storage or installation of units in locations which could fill with water. Please note that the cable ends, even where fitted with protective sleeves, cannot be immersed in water.

**ATTENTION** *These protective covers only provide protection against water spray or similar and are not a watertight seal. The ends of the cables should not be immersed in water, otherwise moisture could enter the connection chamber of the motor.*

**NOTE** *If there is a possibility of water ingress then the cables should be secured so that the ends are above the maximum possible flood level. Take care not to damage the cable or its insulation when doing this!*

### 3.4 Storage of the units

**ATTENTION**      *The Sulzer products must be protected from weather influences such as UV from direct sunlight, high humidity, aggressive dust emissions, mechanical damage, frost etc. The Sulzer original packaging with the relevant transport securing devices (where used) ensures optimum protection of the unit. If the units are exposed to temperatures under 0 °C / 32 °F check that there is no water in the hydraulics, cooling system, or other spaces. In the case of heavy frosts, the units and cable should not be moved if possible. When storing under extreme conditions, e.g. in tropical or desert conditions, suitable additional protective steps should be taken. We would be glad to advise you further.*

**NOTE**              *Sulzer units do not generally require any particular maintenance during storage. By rotating the shaft several times by hand, new lubricating oil is applied to the sealing surfaces, thus ensuring perfect operation of the mechanical seals. The bearings supporting the motor shaft are maintenance-free.*

## 4 Product description

### 4.1 General description

- Hydraulically optimized propeller with high wear resistance.
- The motor shaft is supported in lubricated-for-life, maintenance-free ball bearings.
- The shaft is sealed on the medium side by means of a high quality mechanical seal, which is independent of direction of rotation.
- Oil chamber filled with lubricating oil.

### 4.2 Motor description

- Permanent magnet motor (XRCP 400/500). Starting: variable frequency drive (VFD).
- Three phase squirrel cage motor (XRCP 250/800 PA). Starting: direct on line (D.O.L),/ Star-Delta.
- Rated voltage: 400 V 3~ 50 Hz / 480 V 3~ 60 Hz.
- Other voltages available on request.
- Insulation class F = 155 °C (311 °F), Protection type IP68.
- Medium temperature for continuous operation: + 40 °C (104 °F.)

#### Motor monitoring

- All motors are fitted with temperature monitors that switch off the motor in the case of excessive temperatures. The sensors must be correctly wired into the control panel.

#### Seal monitoring

- The leakage sensor (DI) carries out the seal monitoring function and signals the ingress of moisture by means of a special electronic device (option).

**NOTE**              *Running the unit with the thermal and/or leakage sensors disconnected will invalidate related warranty claims.*

#### Operation with frequency inverters

- All XRCP when **suitably selected**, can be used with frequency inverters. **Observe the EMC-Directive and the installation and operating instructions of the inverter manufacturer!**

## 5 Structural design

### 5.1 XRCP 250/400/500

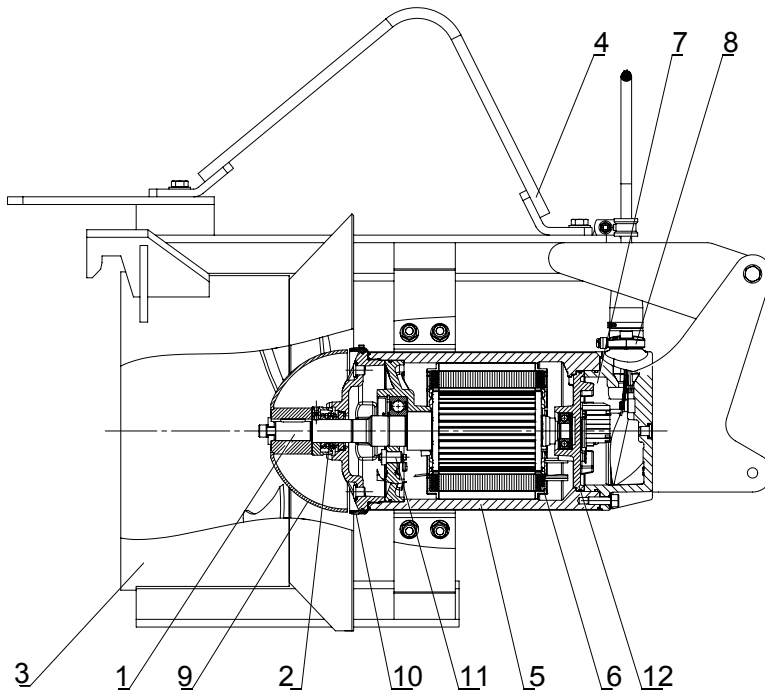

2508-0007

#### Legend

- 1 Shaft unit with rotor and bearings
- 2 Mechanical seal
- 3 Inlet cone
- 4 Lifting hook
- 5 Motor housing
- 6 Stator
- 7 Connection chamber
- 8 Cable inlet
- 9 Propeller
- 10 SD ring
- 11 Leakage sensor (DI)
- 12 Sealing of motor chamber

Figure 6 XRCP 250/400/500

### 5.2 XRCP 800 PA

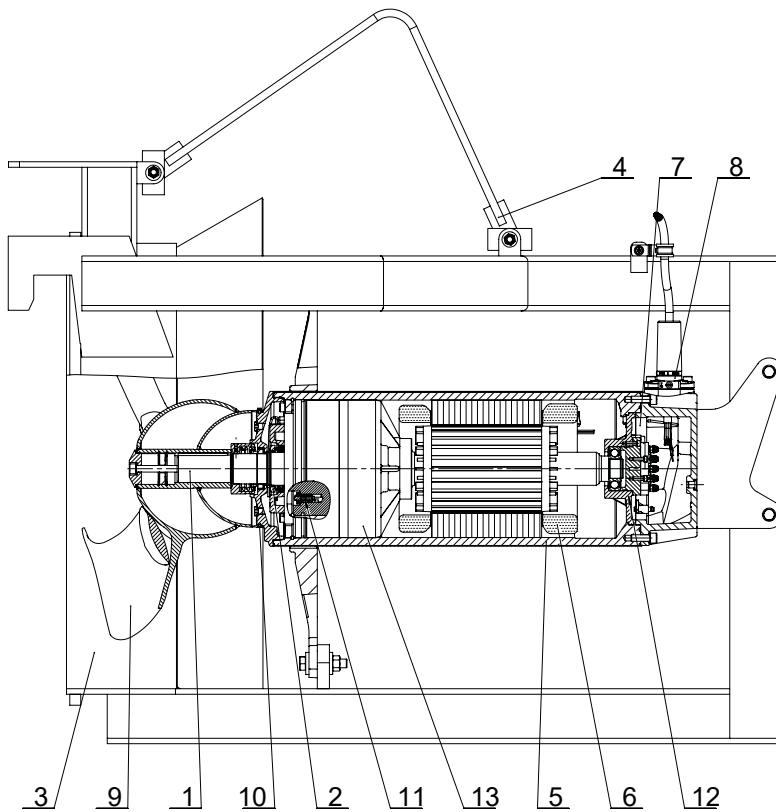

2508-0008

#### Legend

- 1 Shaft unit with rotor and bearings
- 2 Mechanical seal
- 3 Inlet cone
- 4 Lifting hook
- 5 Motor housing
- 6 Stator
- 7 Connection chamber
- 8 Cable inlet
- 9 Propeller
- 10 SD ring
- 11 Leakage sensor (DI)
- 12 Sealing of motor chamber
- 13 Gear

Figure 7 XRCP 800 PA

## 6 Installation



The safety hints in the previous sections must be observed!

The wires (motor cable) are designed according to EN 50525-1, the operating conditions are based on table 14 for special rubber cables. The load capacity of the wires is adapted to an ambient temperature of 40 °C according to table 15 (column 4 for multicore cables, and column 5 for single-core cables), and calculated with a factor for clustering and installation type.

A minimum gap of 1 x outer diameter of the cable used applies when installing.

**ATTENTION** *Twisting should not occur. The cables should not touch anything, not grabbed or bundled. When extending, recalculate the wire cross-section according to EN 50525-1, irrespective of the cable and installation type, cluster etc.!*

In pump stations/tanks potential bonding must be carried out in accordance with EN 60079-14:2014 [Ex] or IEC 60364-5-54 [non-Ex] (Regulations for the installation of pipe lines, protective measures in power plants).

### 6.1 Installation general



Care must be taken that the connection cables are positioned that they cannot be caught up in the propeller blades and that they are not subjected to tension.



The electrical connection is carried out in accordance with *section 7 Electrical connection*.

**NOTE**

***We recommend that Sulzer installation accessories are used for the installation of the XRCP recirculation pumps.***

### 6.2 Disassembling/assembling the propeller

#### 6.2.1 Propeller disassembly / assembly, XRCP 250/400/500

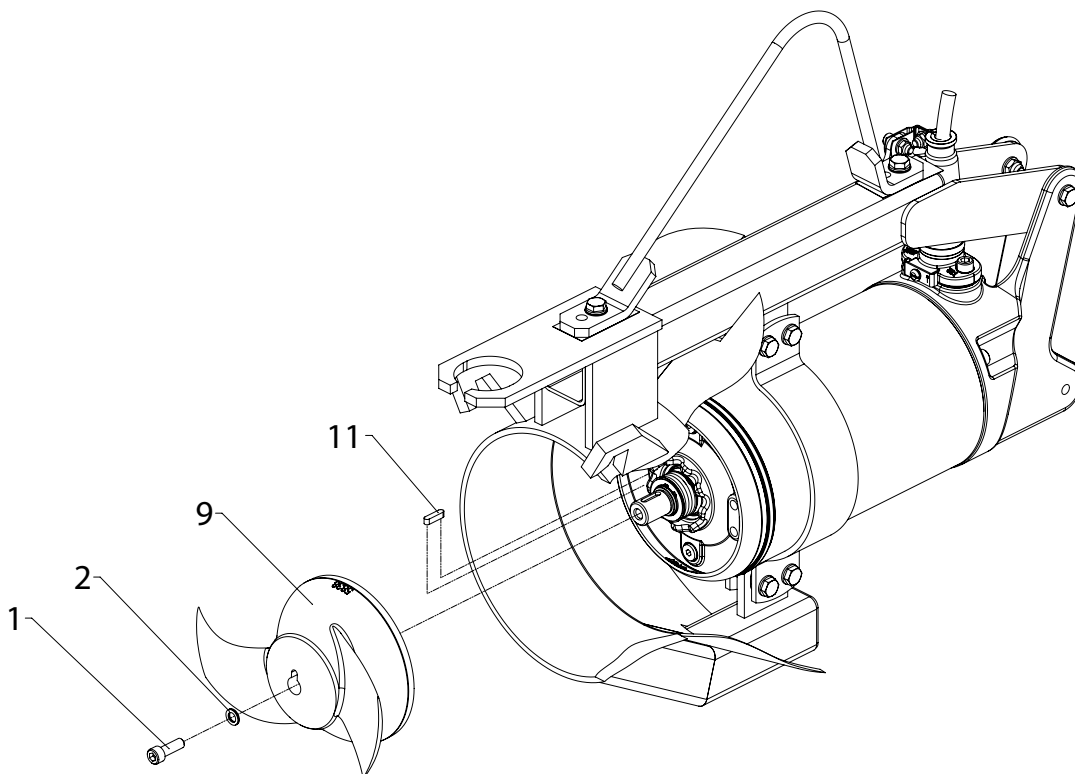

Figure 8 XRCP 250 propeller disassembly / assembly

2508-0009



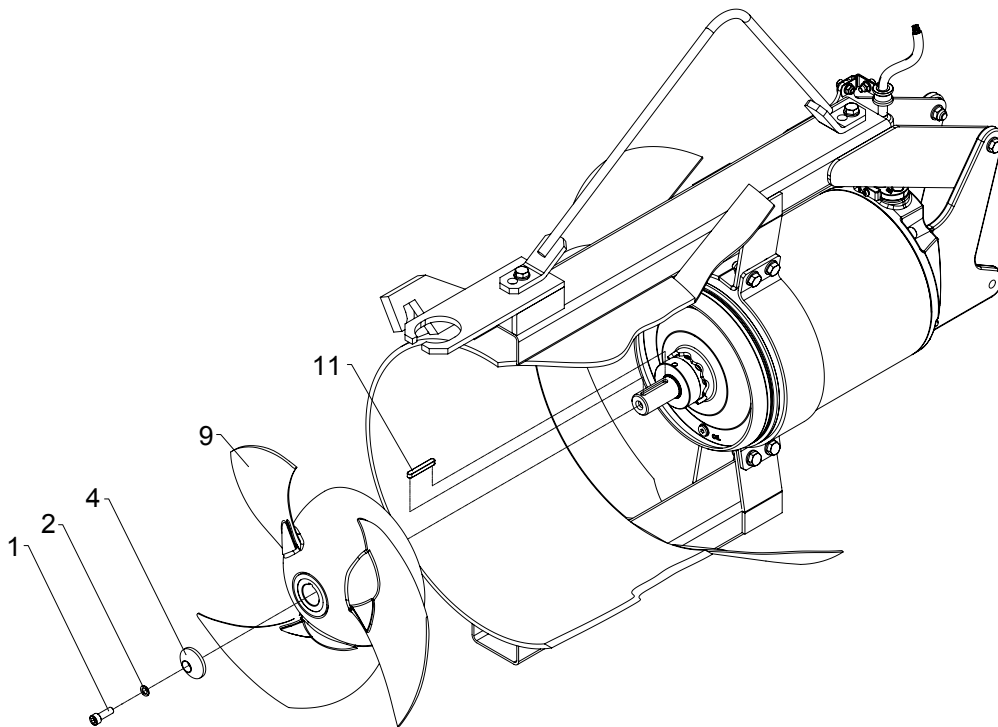

Figure 9 XRCP 400/500 propeller disassembly / assembly

### 6.2.2 Propeller disassembly, XRCP 250/400/500

- Loosen and remove the cylinder screw (8/1; 9/1), the locking washer (8/2; 9/2) and rotor disk (9/4).
- Pull the propeller (8/9; 9/9) off the motor shaft

### 6.2.3 Propeller disassembly / assembly, XRCP 800 PA

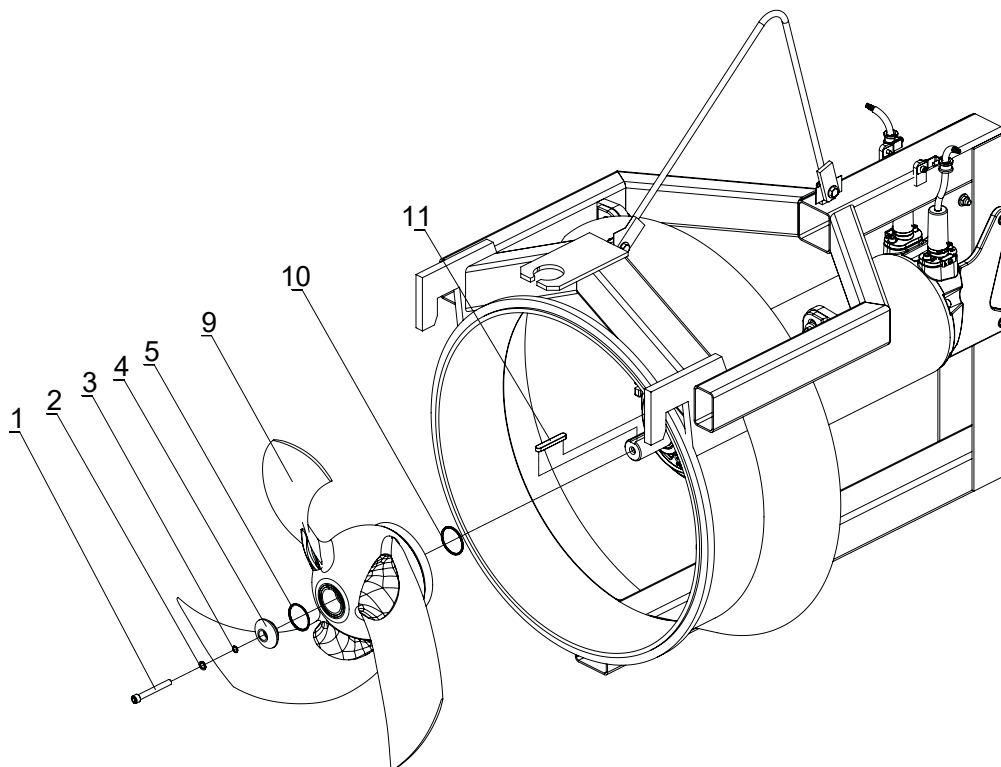
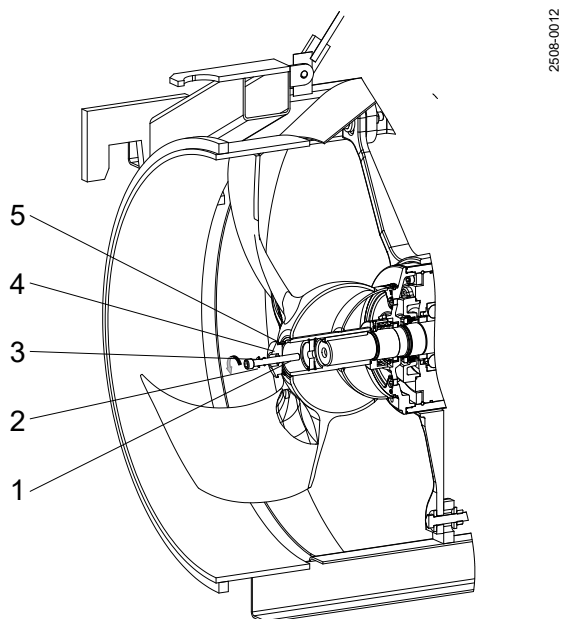
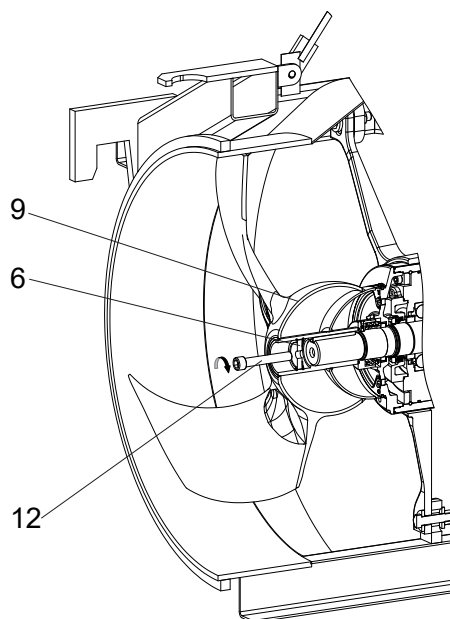

Figure 10 Propeller Disassembly / assembly, XRCP 800 PA

## 6.2.4 Propeller disassembly, XRCP 800 PA



2508-0012



2508-0013

Figure 11.1 Propeller disassembly, XRCP 800 PA

Figure 11.2 Loosening the propeller XRCP 800 PA

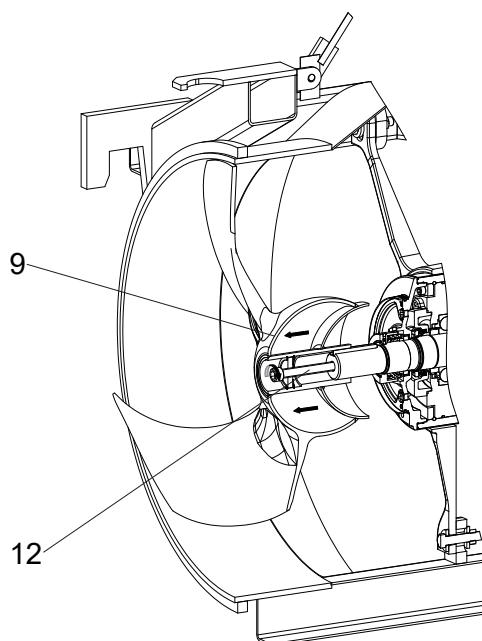

2508-0014

Figure 11.3 Removing the propeller, XRCP 800 PA

- Loosen and remove the cylinder screw (11.1/1), the locking washer (11.1/2), rotor disk (11.1/4), o-ring (11.1/3, 11.1/5).
- To release the propeller, screw an M16 x 110 cylinder screw (11.2/11) into the disk (11.2/6) until the propeller detaches from the motor shaft.
- Pull the propeller (11.3/9) off the motor shaft.

### Legend

1	Cylinder screw	5	O-ring	9	Propeller
2	Locking washers	6	Disc	10	O-ring
3	O-ring			11	Feather key
4	Rotor disc			12	Cylinder screw

### 6.2.5 Propeller assembly, XRCP 250/400/500

**ATTENTION** Pay attention to the correct installation position of the locking washers (figure 12 Installation position of the locking washers) and the prescribed torque!

- Lightly grease the propeller hub and shaft stub.
- If necessary, insert the feather key (8/11; 9/11) into the keyway of the motor shaft.
- Align the propeller (8/9; 9/9). The keyway of the propeller hub must be pushed over the feather key (8/11; 9/11) as far as possible. Insert the rotor disk (9/4).
- Insert the locking washer (8/2; 9/2) together with the cylinder screw (8/1; 9/1). Pay attention to the installation position of the locking washer (8/2; 9/2) - see figure 12 Installation position of the Nord-Lock® locking washers.
- Tighten the cylinder-head screw (9/1; 10/1) to a torque of 33 Nm.

### 6.2.6 Propeller assembly, XRCP 800 PA

- Lightly grease the propeller hub and shaft stub. If necessary, insert the feather key (10/11) into the keyway of the motor shaft.
- Insert the o-ring (10/10) over the feather key (10/11) into the groove on the cover of the axial face seal.
- Align the propeller (10/9). The keyway of the propeller hub must be pushed over the feather key (10/11) as far as possible.
- Insert the rotor disk (10/4) together with the o-ring (10/5) into the bore of the propeller (10/9).
- Insert the locking ring (10/2) and o-ring (10/3) together with the cylinder screw (10/1). Pay attention to the installation position of the locking washer (10/2) - see figure 12 Installation position of the Nord-Lock® locking washers.
- Tighten the cylinder-head screw (10/1) to a torque of 56 Nm.

**ATTENTION** Do not use any products containing molybdenum disulphide!

### 6.3 Tightening torque

Tightening torque for Sulzer stainless steel screws A4-70:							
Thread	M6	M8	M10	M12	M16	M20	M24
Tightening torque	6.9 Nm	17 Nm	33 Nm	56 Nm	136 Nm	267 Nm	460 Nm

### 6.4 Fitting position of the Nord-Lock® securing washers

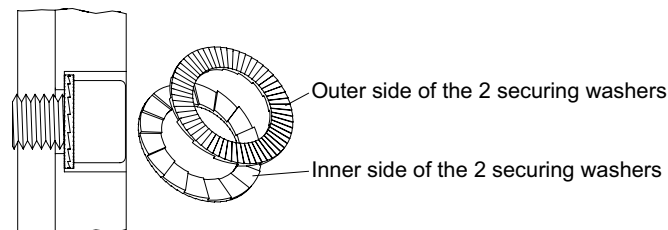

Figure 12 Correct fitting position of the Nord-Lock® securing washers

6000-2930

## 6.5 Installation example with ABS lifting unit

2505-0016

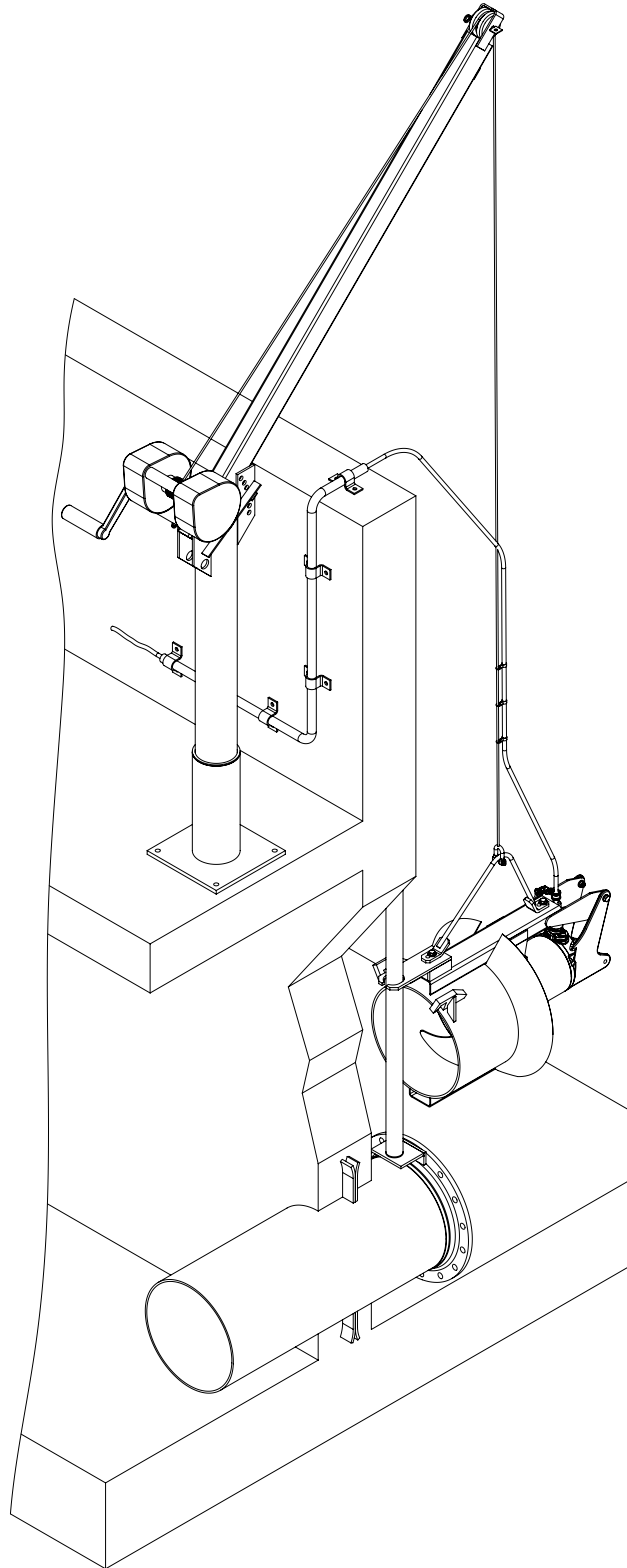

Figure 13 Installation example with ABS lifting unit 5 kN

## 6.6 Guide tube installation



The safety hints in the previous sections must be observed!

**ATTENTION** *The discharge line and the required flange DIN EN 1092-1 PN6 should be installed on site before starting the installation of the guide tube. The DIN-flange should be installed so that none of the holes in the flange are on the axis line but are symmetrically on either side of it. Ensure that the DIN flange is securely fixed in the concrete.*

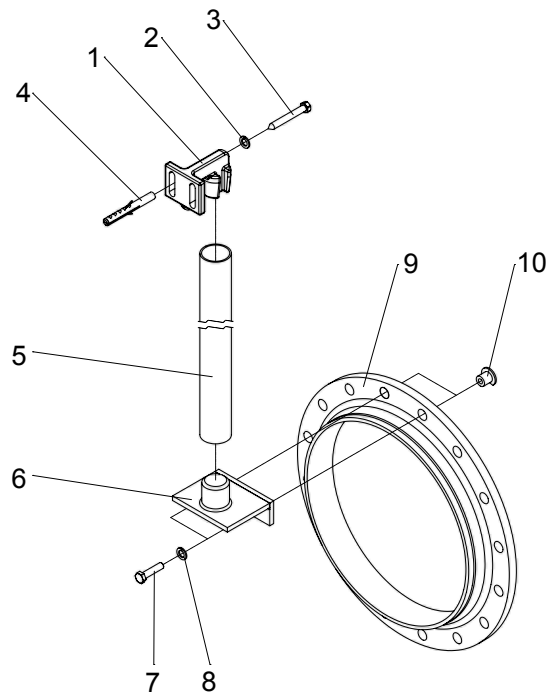

2508-0017

Figure 14  
Guide tube installation XRCP 250/400/500/800 PA

- Place bracket (14/6) on the DIN-flange (14/9) and fasten using hex nuts (14/7) together with spring washers (14/8) and the special nuts (14/10).

**ATTENTION** *The flattened edge of the special nuts (14/10) must point towards the flange centre.*

- Position the tube retainer (14/1) vertically over the bracket (14/6). Mount with the aid of the wall plugs (14/4) but do not tighten yet!
- Place the guide tube (14/5) alongside the conical section of the bracket (14/6) and determine the required length. To do this measure the upper edge of the tube retainer (14/1).
- Cut the guide tube (14/5) to the required length and place it on the conical portion of the bracket (14/6).
- Press the tube retainer (14/1) into the guide tube (14/5), so that no vertical play remains. Now tighten the hex screws (14/3) using the spring washers.(14/2).

## 6.7 Securing and positioning of the motor connection cables of the XRCP



The safety hints in the previous sections must be observed!

### NOTE

*The cable holders described here are not supplied as part of the standard execution of the XRCP.*

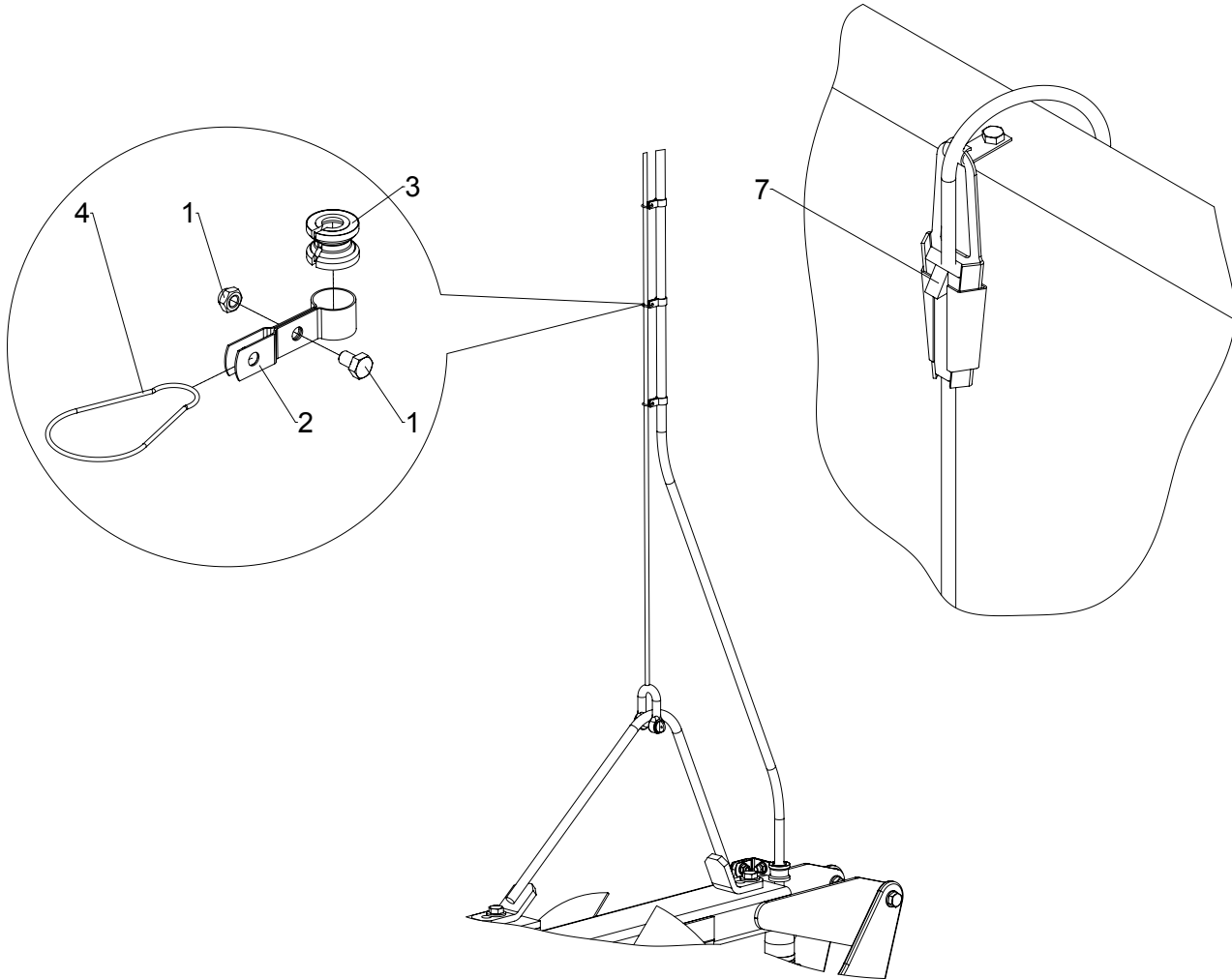

2508-0019

Figure 15 Securing and positioning of the motor connection cables of the XRCP

- Place the cable holder (15/2) with rubber sleeve (15/3) on the connection cable close to the XRCP itself and tighten using hex screw (15/1).
- Connect the snap hook (15/4) to the cable holder (15/2) and attach to the wire rope.



Care must be taken that the connection cables are positioned that they cannot be caught up in the propeller blades and that they are not subjected to tension.

- Assemble all other cable holders in a similar manner. The spacing can be increased as the distance from the XRCP increases.
- Hang the connection cable into the cable hook using the strain relief (15/7).



The electrical connection is carried out in accordance with *section 7 Electrical connection*.

## 6.8 Lowering of the XRCP along the guide tube



The safety hints in the previous sections must be observed!

The XRCP together with the guide piece is connected into the guide tube (see Figure 17) and lowered along it until it automatically sits in its final position. When doing this, carefully feed the power cable downwards at the same time.

The lifting hook is designed to tilt the XRCP towards the propeller end when suspended by the hoist (see Figure 16). This is necessary to ensure that the unit lowers correctly on the guide tube, and must be checked before installing.

If the unit tilts in the opposite direction it means that the lifting hook is incorrectly fitted and it must be refitted in the reverse position.

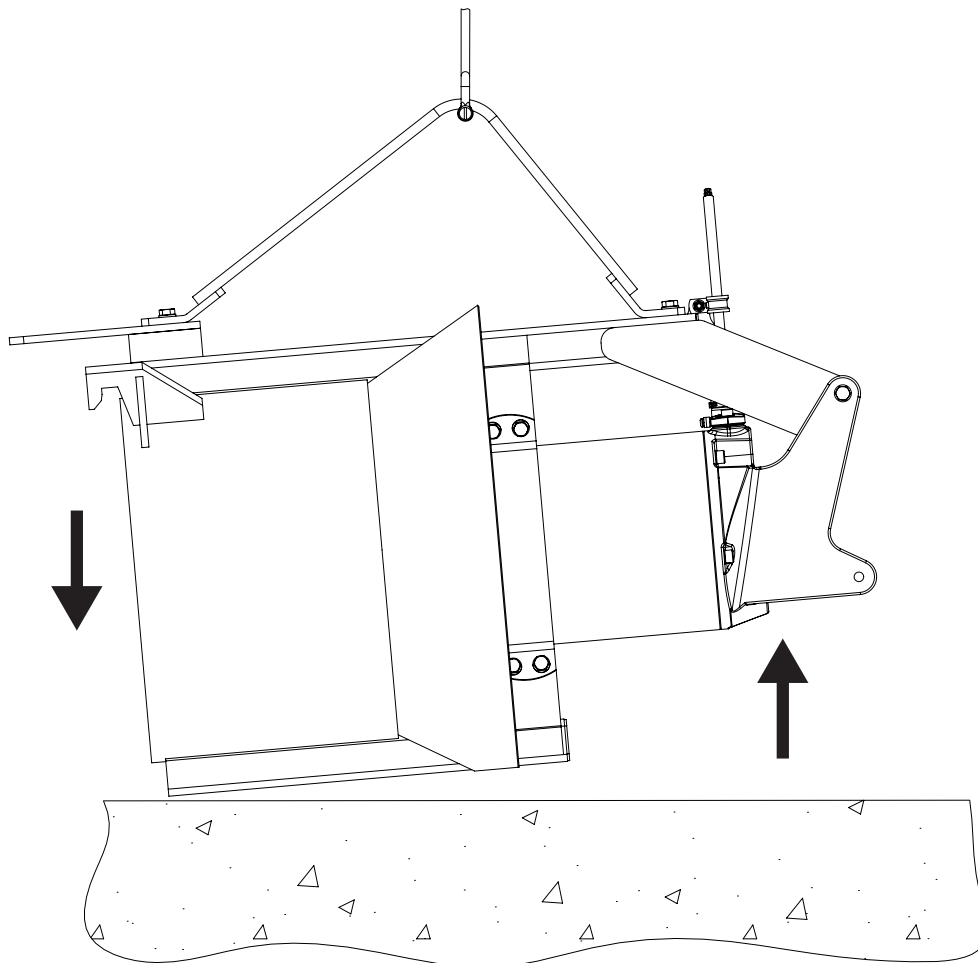

2508-0015

Figure 16. Checking installation angle of pump.

**ATTENTION**      **The power cable should be connected to the wire rope in such a manner that it cannot become entangled in the propeller and that it is not subjected to any tension.**

After lowering of the XRCP the tension of the wire rope should be released.

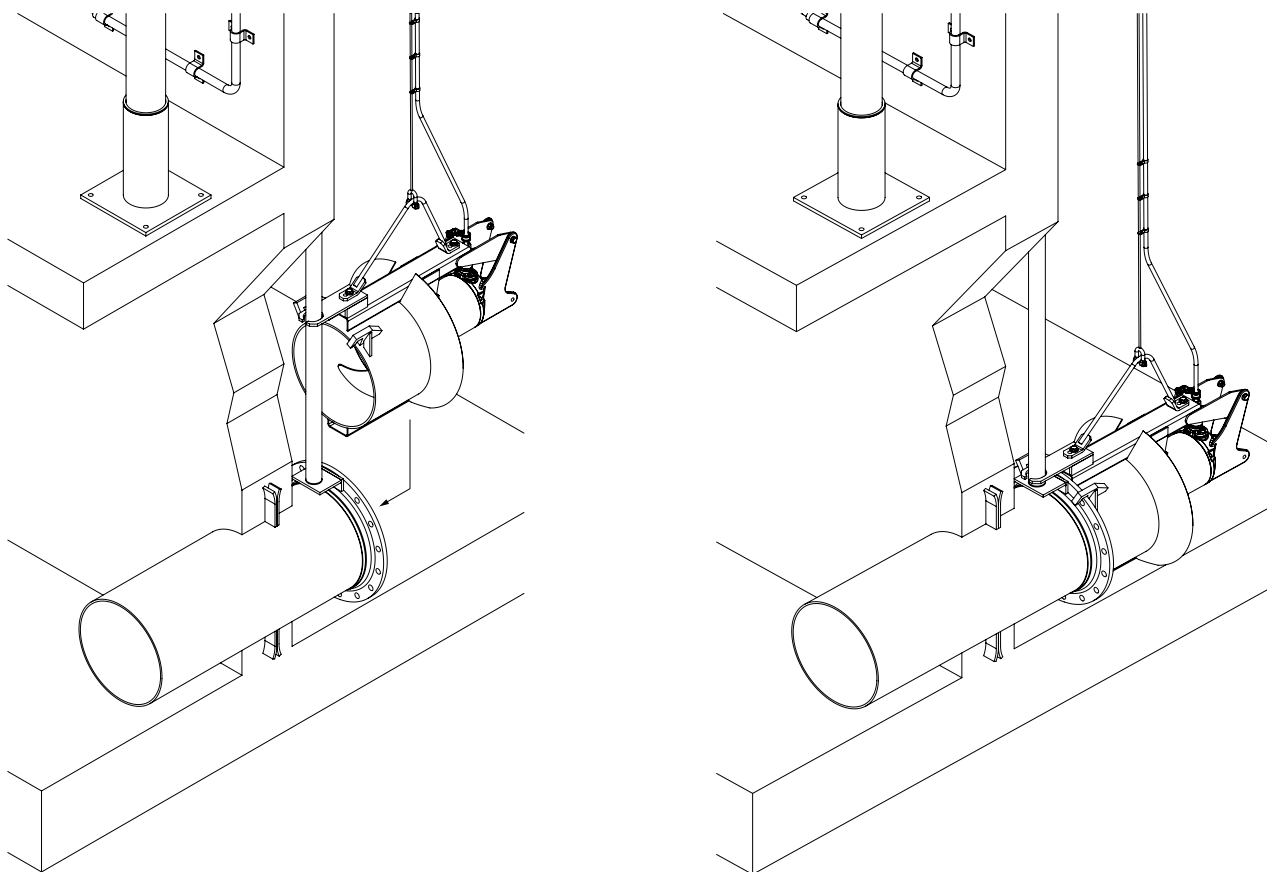

Figure 17 XRCP lowering / XRCP connected

## 7 Electrical connection



The safety hints in the previous sections must be observed!

Before commissioning, an expert should check that one of the necessary electrical protective devices is available. Earthing, neutral, earth leakage circuit breakers, etc. must comply with the regulations of the local electricity supply authority, and a qualified person should check that these are in perfect order.

**ATTENTION** *The power supply system on site must comply with local regulations with regard to cross-sectional area and maximum voltage drop. The voltage stated on the nameplate of the pump must correspond to that of the mains*

**ATTENTION** *Before startup, the date and the time must be set. For this purpose, refer to the Danfoss VLT FC202 product manual. These settings must be made after every mains failure, disconnection from the mains supply, or renewed installation. The setting parameter can be called up via the Quick-Menu on the LCD display.*



The incoming power supply, as well as the connection of the unit itself to the terminals on the control panel, must comply with the circuit diagram of the control panel as well as the motor connection diagrams, and must be carried out by a qualified person.

The power supply cable must be protected by an adequately dimensioned slow-blow fuse corresponding to the rated power of the unit.

In the case of units supplied with a standard control panel this must be protected from dampness and installed above flood level by means of a correctly fitted CEE earthed socket.



**ATTENTION**

The only method of starting allowed is that specified in chapter 1.6 Technical data or on the nameplate. If you want to use other starting methods please consult the manufacturer.

In the case where a control panel is not supplied as standard the unit must only be operated with a motor protection switch with overload relay and thermal sensors connected.

**7.1 Connection diagram VFD (only for XRCP 400, XRCP 500)**

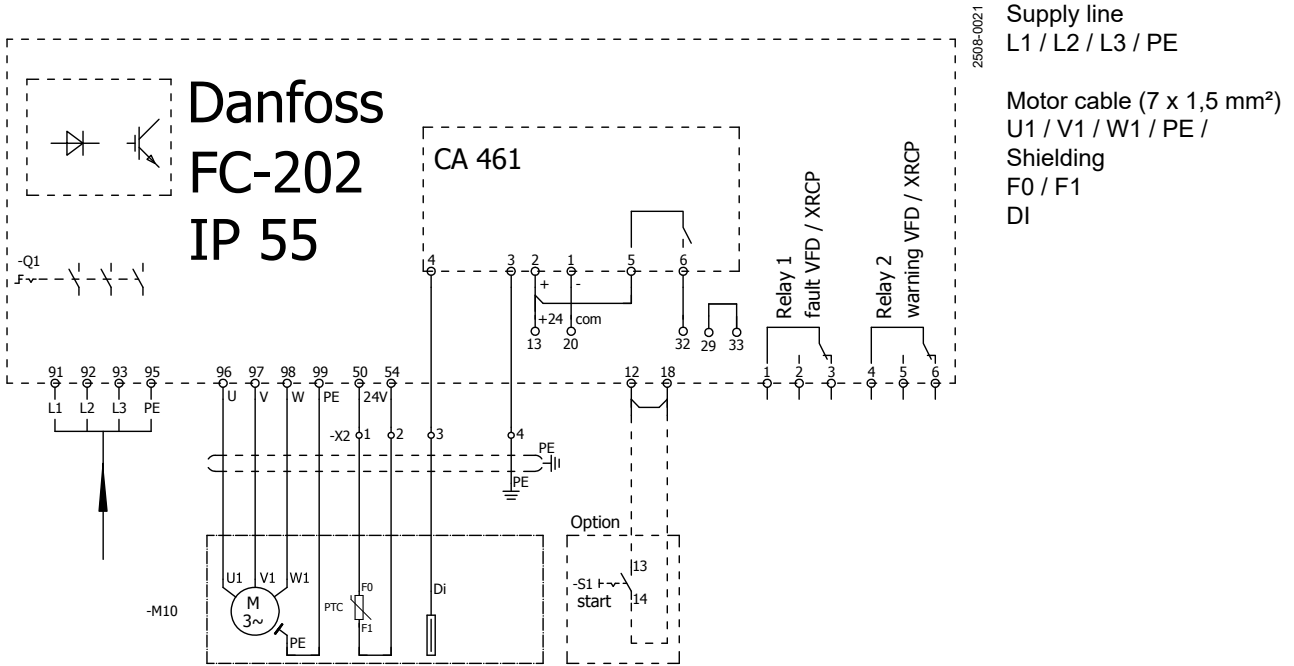
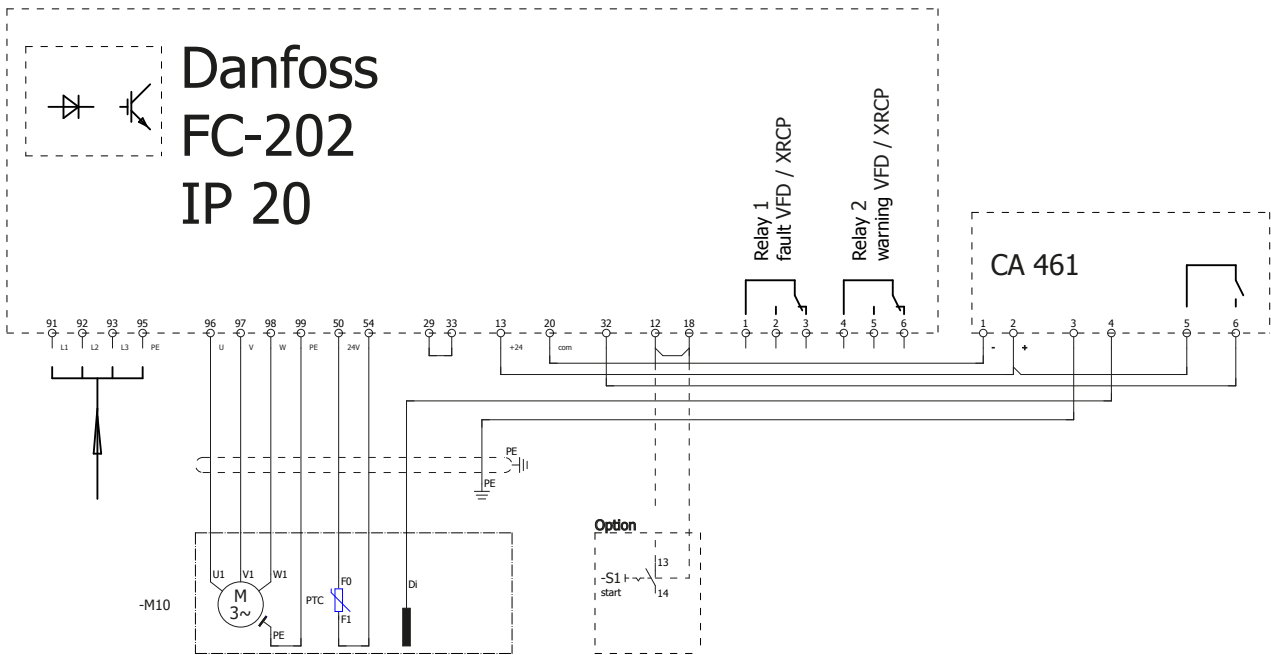

Figure 18: Connection diagram VFD IP55



Supply line L1 / L2 / L3 / PE; Motor cable (7 x 1,5 mm<sup>2</sup>) U1 / V1 / W1 / PE; Shielding F0 / F1 DI

Figure 19 Connection diagram VFD IP20

## 7.2 Standard connection diagrams - mains voltage 380 - 420 V at 50 Hz / 480 V at 60 Hz

### 7.2.1 Standard connection diagram XRCP 250

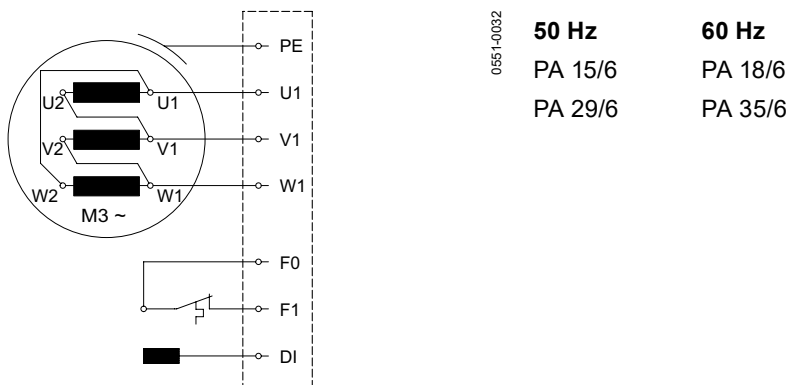

Figure 20 One power cable with integrated control leads XRCP 250

### 7.2.2 Standard connection diagram XRCP 800 PA

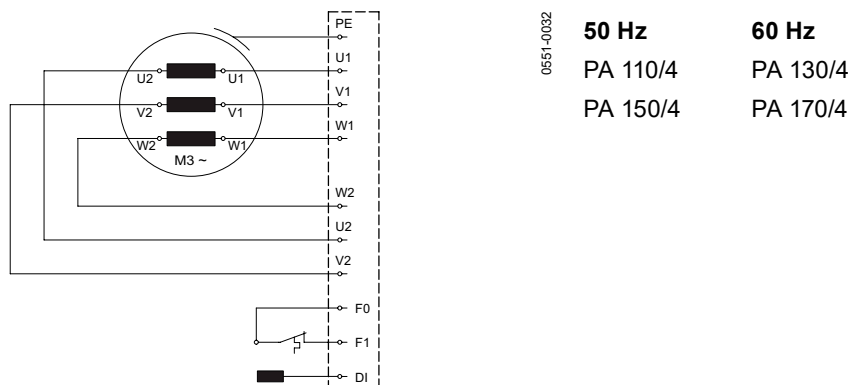

Figure 21 One power cable with integrated control leads XRCP 800 PA

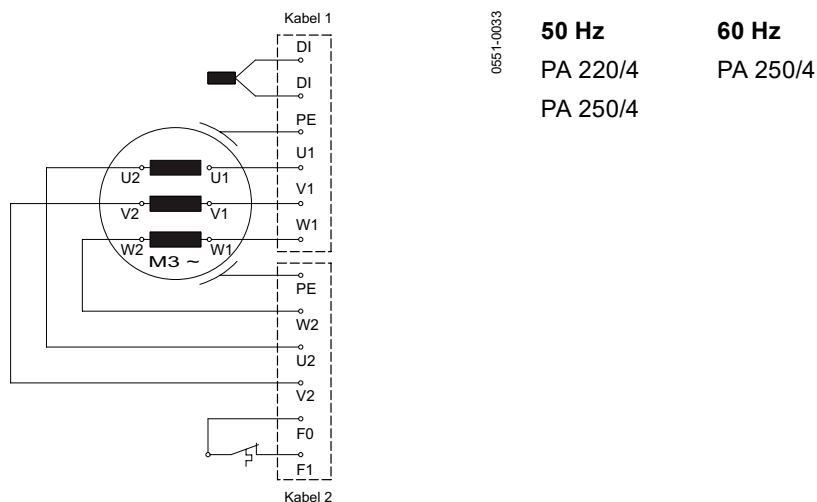

Figure 22 Two power cables with integrated control leads XRCP 800 PA

### 7.3 Lead designations

Direct starting in star					 0562-0033
	L1	L2	L3	Join	
North America	T1 (U1)*	T2 (V1)*	T3 (W1)*		
Sulzer/Factory Standard	U1	V1	W1	U2 & V2 & W2	
Direct starting in delta					 0562-0034
	L1	L2	L3	-	
North America	T1 (U1)*	T2 (V1)*	T3 (W1)*	-	
Sulzer/Factory Standard	U1; W2	V1; U2	W1; V2	-	

\*Optional labeling possible.

### 7.4 Motor monitoring

All motors are fitted with temperature monitors which switch off the motor in the case of excessive temperatures. The sensor must be correctly wired into the control panel.



The thermal monitoring circuit (F1) must be wired into the motor contactors in such a manner that a manual reset is required.

**ATTENTION** *The temperature limiting switches may only be operated as specified by the manufacturer (See following table).*

Operating voltage...AC	<b>100 V to 500 V ~</b>
Rated voltage AC	<b>250 V</b>
Rated current AC $\cos \varphi = 1.0$	<b>2.5 A</b>
Rated current AC $\cos \varphi = 0.6$	<b>1.6 A</b>
Max. switching current at $I_N$	<b>5.0 A</b>

## 7.5 Connection of the seal monitoring unit to the control panel

The standard versions of the units are fitted as standard with leakage sensors (DI) that monitor the state of the sealing. In order to integrate the leakage sensors into the control panel it is necessary to fit a Sulzer leakage control module and connect it in accordance with the wiring diagram below.

**ATTENTION** *If the leakage sensor (DI) is activated the unit must be immediately taken out of service. Please contact your Sulzer service centre.*

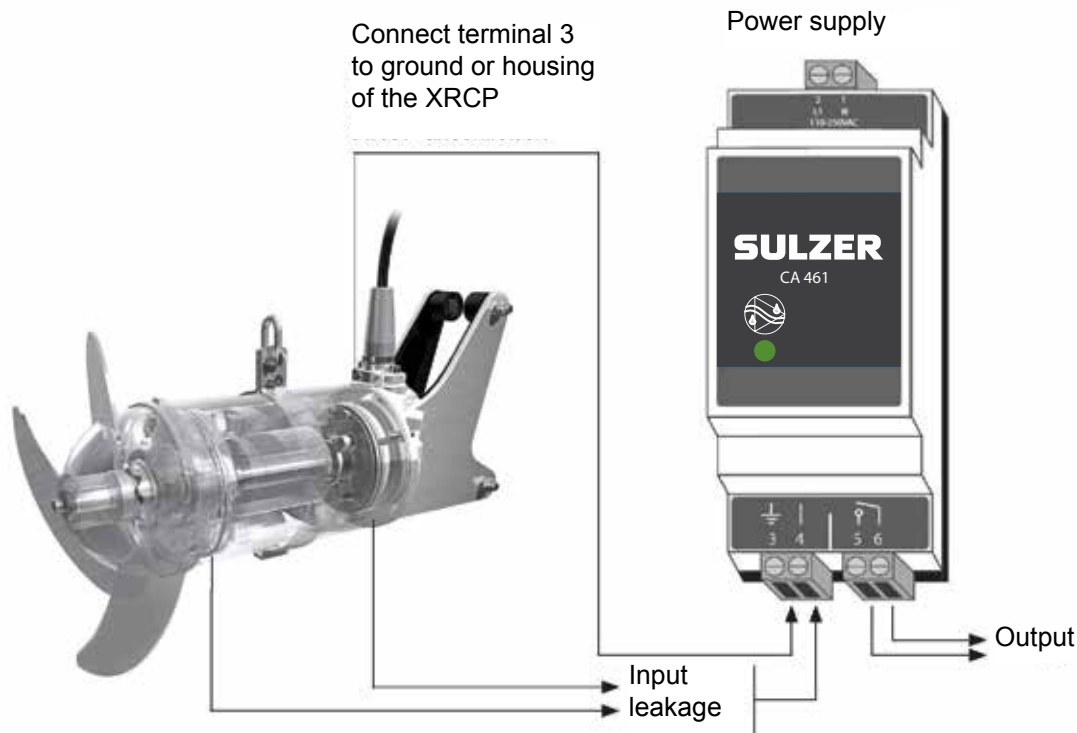

Figure 23 Sulzer leakage relay CA 461

### Electronic amplifier for 50 Hz / 60 Hz

110 - 230 V, AC (CSA). Part No.: 16907010.

18 - 36 V, DC (CSA). Part No.: 16907011.

**ATTENTION** *Maximum relay contact loading: 2 Ampere.*

**ATTENTION** *It is very important to note that with the connection example above it is not possible to identify which sensor/alarm is being activated. As an alternative Sulzer highly recommends to use a separate CA 461 module for each sensor/input, to allow not only identification but also to prompt to the appropriate response to the alarm category/severity.*

Multiple-input leakage control modules are also available. Please consult with your local Sulzer representative.

## 7.6 Operation with frequency inverters (for XRCP 250 and XRCP 800 PA)

The stator design and the insulation grade of the motors from Sulzer means that they are suitable for usage with frequency inverters. It is however essential that the following conditions are met:

- The guidelines for EMC (electromagnetic compatibility) are complied with.
- Speed/torque curves for motors driven by frequency inverters can be found in our product selection range.
- Explosion-proof motors must be equipped with thermistors (PTC temperature sensors) if operated in hazardous areas (ATEX Zone 1 and 2).
- Machines designated as Ex machines may never, without exception, be operated using a mains frequency that is greater than the maximum of 50 Hz or 60 Hz as indicated on the nameplate. Make sure that the rated current specified on the nameplate is not exceeded after starting the motor. The maximum number of starts according to the motor datasheet may not be exceeded.
- Machines that are not designated as Ex machines may only be operated using the mains frequency indicated on the nameplate. Greater frequencies can be used but only after consulting with and receiving permission from the Sulzer manufacturing plant.
- For operation of Ex motors on frequency inverters special requirements in relation to the tripping times of the thermo control elements, must be observed.
- The lowest frequency must be set so that it does not fall below 25 Hz.
- The maximum frequency must be set so that the rated power of the motor is not exceeded.

Modern frequency inverters use higher wave frequencies and a steeper rise on the edge of the voltage wave. This means that motor losses and motor noise is reduced. Unfortunately these inverter output signals cause higher voltage spikes in the stator. Experience has shown that, depending on rated voltage and the length of the cable between the inverter and the motor, these voltage spikes can adversely affect the life of the motor. In order to avoid this, inverters of this type must be equipped with sinus filters when used in the critical zone (see Figure 24). The sinus filter chosen must be suitable for the inverter with regard to rated voltage, inverter wave frequency, rated current of the inverter, and maximum inverter output frequency. Make sure that the rated voltage is supplied to the terminal board of the motor.

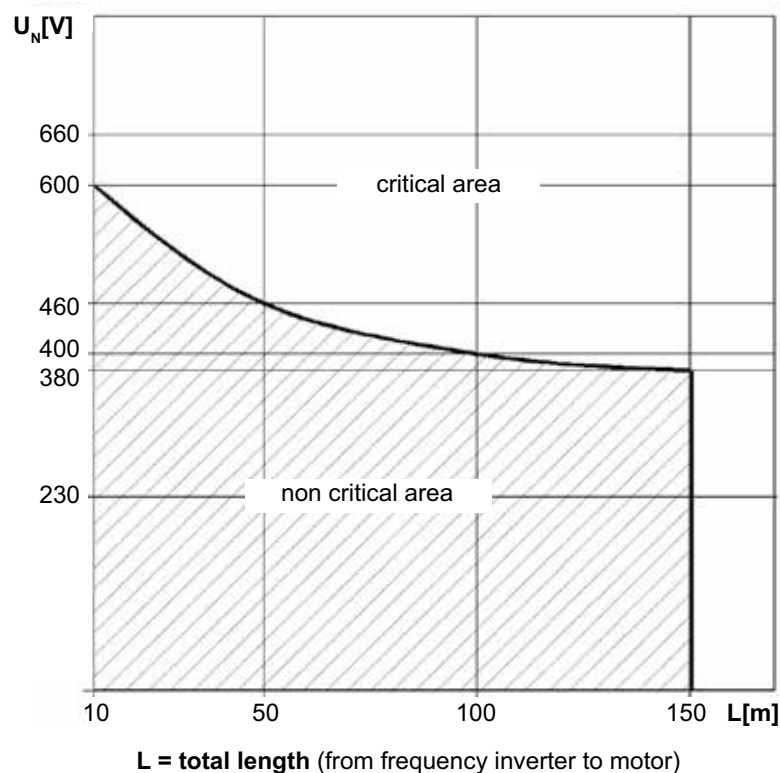

Figure 24 Critical/non critical area

0562-0012

### 7.7 Soft starter (Option)

For units > 15 kW we recommend the use of soft starter.

**ATTENTION** The units must be connected DOL when used with soft starters.

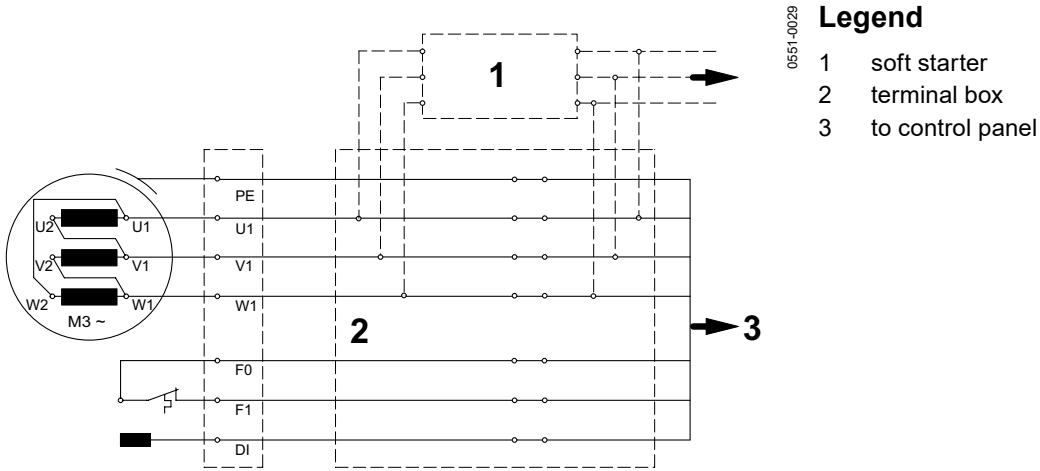

Figure 25 Wiring diagram with soft starter (option)

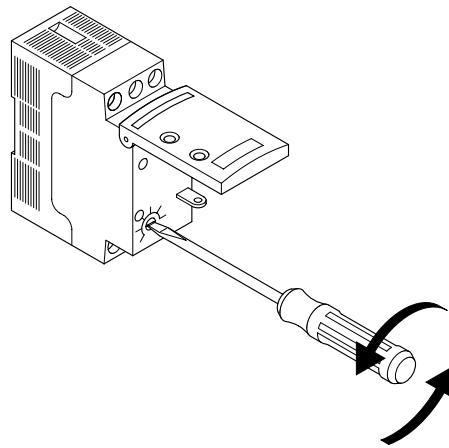

Figure 26 Testing and adjustment of soft starter

#### Testing and adjustment of soft starter:

**ATTENTION** For the first test adjust the potentiometer in position C.

For further information consult the installation and operating instructions of the soft start manufacturer. These are supplied with the unit.

#### Test:

- First test with potentiometer setting “C”.

#### Setting:

- Set to the **lowest possible starting torque** (within the adjustment range possible).
- Set to the **longest possible starting time** (within the adjustment range possible).

## 8 Direction of rotation

When the units are being commissioned for the first time, and also when used on a new site, the direction of rotation must be carefully checked by a qualified person.

### 8.1 Checking direction of rotation

#### XRCP 250 / 400 / 500 / 800 PA

The direction of the propeller rotation is correct if the propeller, when viewed from the rear over the motor housing, rotates in a clockwise direction (see arrows).

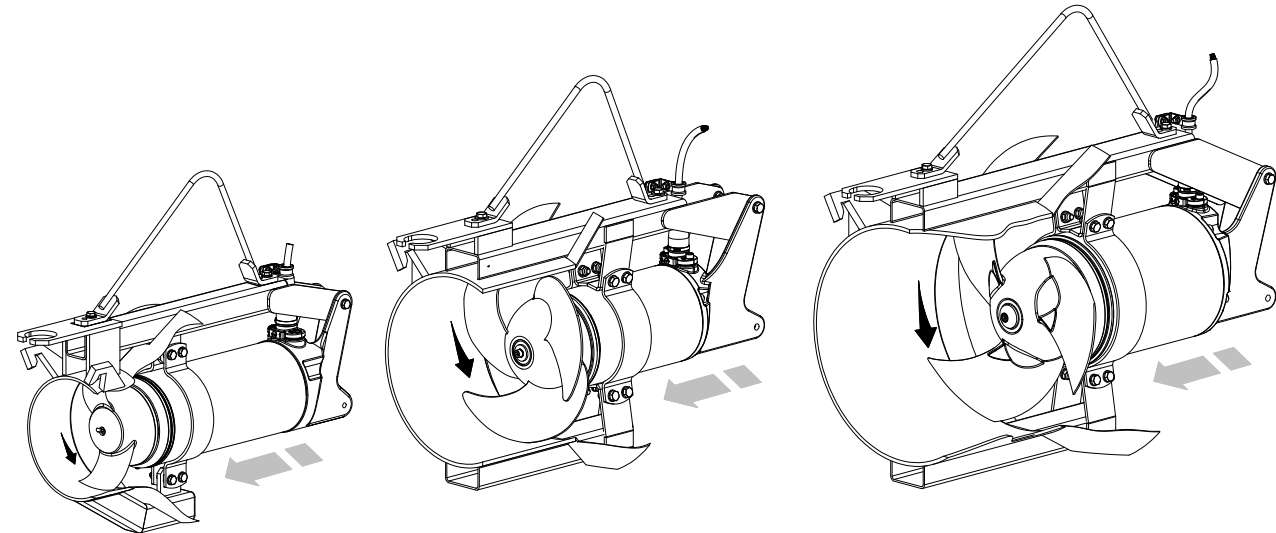

2508-0023

Figure 27 Checking direction of rotation XRCP 250/400/500

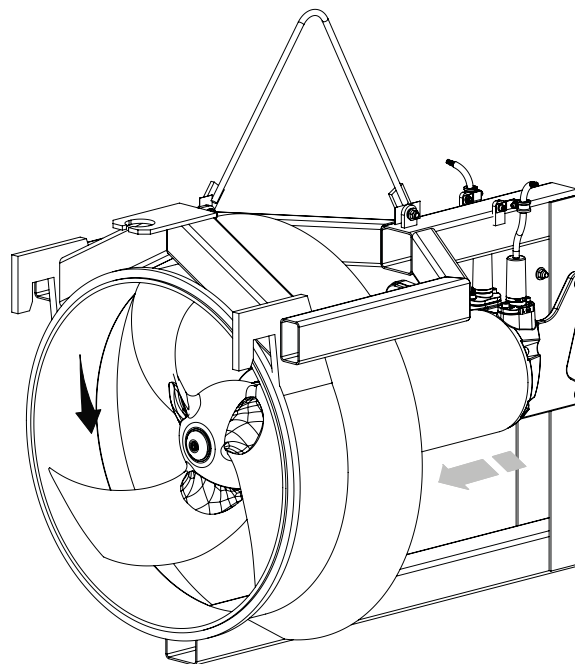

2508-0024

Figure 28 Checking direction of rotation XRCP 800 PA



When checking the direction of rotation take care that no injury can be caused by the rotation of the propeller or the resulting airflow. Do not place a hand or other part of the body near the propeller or the hydraulics!



The direction of rotation should only be altered by a qualified person.



When carrying out the direction of rotation check, as well as when starting the unit, pay attention to the Start reaction. This can be very powerful.

**NOTE** *If a number of units are connected to a single control panel then each unit must be individually checked.*

**ATTENTION** *The mains supply in the control panel must have a clockwise sense of rotation. If the units are connected in accordance with the wiring diagram and the lead designations the direction of rotation will be correct.*

## 8.2 Changing direction of rotation



The safety hints in the previous sections must be observed!



Changing the direction of rotation must only be carried out by a qualified person.

If the direction of rotation is incorrect then this is altered by changing over two phases of the power supply cable in the control panel. The direction of rotation should then be rechecked.

**NOTE** *The direction of rotation measuring device monitors the direction of rotation of the mains supply or that of an emergency generator.*

## 9 Commissioning



The safety hints in the previous sections must be observed!

Before commissioning, the unit should be checked and a functional test carried out. Particular attention should be paid to the following:

- Have the electrical connections been carried out in accordance with regulations?
- Have the thermal sensors/limiters been connected?
- Is the seal monitoring device (where fitted) correctly installed?
- Is the motor overload switch correctly set?
- Have the power and control circuit cables been correctly fitted?
- Has the motor connection cable been laid in such a manner that it cannot be caught up by the rotating body?
- Has the minimum submergence level been observed? (See Section 1.7 Dimensions and weights).



## 10 Maintenance



The safety hints in the previous sections must be observed!

In particular, the advice regarding maintenance in *paragraph 3.2* of the separate booklet Safety Instructions for Sulzer Products Type ABS are to be observed.

### 10.1 General maintenance hints



Before commencing any maintenance work the unit should be completely disconnected from the mains by a qualified person and care should be taken that it cannot be inadvertently switched back on.

#### NOTE

***The maintenance hints given here are not designed for “do-it-yourself” repairs as special technical knowledge is required.***



Repair work on explosion-proof motors may only be carried out in approved workshops by approved personnel using original parts supplied by the manufacturer. Otherwise the Ex-approvals no longer apply.

Sulzer units are reliable quality products each being subjected to careful final inspection. Lubricated-for-life ball bearings together with monitoring devices ensure optimum pump reliability provided that the unit has been connected and operated in accordance with the operating instructions.

Should, nevertheless, a malfunction occur, do not improvise but ask your Sulzer customer service department for assistance.

This applies particularly if the unit is continually switched off by the current overload in the control panel, by the thermal sensors/limiters of the thermo-control system or by the seal monitoring system (DI).

The Sulzer service organisation would be pleased to advise you on any applications you may have and to assist you in solving your aerating problems.

#### NOTE

***The Sulzer warranty conditions are only valid provided that any repair work has been carried out in Sulzer approved workshops and where original Sulzer spare parts have been used.***

#### NOTE

***In the case of repair work, „Table 1“ from IEC60079-1 may not be applied. In this case please contact Sulzer after sales service!***

#### ATTENTION

***Regular checks are highly recommended and other checks are prescribed regulations after specific intervals. This ensures a long life time and trouble-free operation of the units (see section 10.2 Maintenance XRCP).***

### 10.2 Maintenance XRCP



The safety hints in the previous sections must be observed!

Inspections carried through at regular intervals and preventive maintenance guarantee trouble-free operation. For this reason the complete unit should be cleaned thoroughly on a regular basis, maintained and inspected. For this purpose one has to take special care that all parts of the unit are in a good condition and that the operational security is guaranteed. The inspection period is determined by the type of usage of the units, but should however not exceed one year.

The maintenance and inspection work must be carried through corresponding to the subsequent inspection plan. The executed work must be documented in the attached inspection list. In case of non-observance the manufacturer's warranty does not apply!

### 10.3 Faults

In addition to the maintenance and inspection tasks described in section *10.4 Inspection and maintenance intervals for XRCP* an urgent check of the unit and installation should be carried out if heavy vibrations develop or uneven flow patterns occur.

**Possible causes:**

- Wrong direction of rotation of the propeller.
- Propeller is damaged.
- Restriction to the free inflow or outflow in the area of the XRCP inflow cone.
- Parts of the Installation, such as bracket or coupling parts have become defective or become loose.

In these cases the unit should be immediately switched off and inspected. If no fault can be found or the fault remains after it has apparently been corrected the unit should be left switched off. The same applies also where the current overload in the control panel regularly trips where the DI seal monitor or the temperature sensors in the stator are activated. We recommend that in such cases you contact the local Sulzer Service Centre.

### 10.4 Inspection and maintenance intervals for XRCP.



The safety hints in the previous sections must be observed!

<b>PERIOD OF TIME:</b>	<b>Regulation: once a month</b>
<b>ACTIVITY:</b>	Cleaning and inspection of the power and control circuit cables.
<b>DESCRIPTION:</b>	Once a month (more frequently - for example - in difficult application cases where the medium is heavily polluted with fibrous matter) the power and control circuit cables should be cleaned. In particular fibrous materials must be removed. Part of the regular maintenance is also the inspection of the motor cables. These must be checked for scratches, fissures, bubbles or crushing.
<b>MEASURE:</b>	Damaged power and control circuit cables must be replaced in all cases. Please contact your local Sulzer Service Centre.

<b>PERIOD OF TIME:</b>	<b>Recommendation: once a month</b>
<b>ACTIVITY:</b>	Check the current consumption at the ampere meter.
<b>DESCRIPTION:</b>	With normal operation the current consumption is constant. Occasional current fluctuations result from the constitution of the material being mixed.
<b>MEASURE:</b>	If the current consumption is too high for a longer period during normal operation please contact your local Sulzer Service Centre.

<b>PERIOD OF TIME:</b>	<b>Regulation: every 3 months</b>
<b>ACTIVITY:</b>	Inspection of the propeller and the SD ring (Solids-Deflection-Ring).
<b>DESCRIPTION:</b>	The propeller should be inspected carefully. The propeller might show spots of rupture and wear due to strongly abrasive or aggressive mixing material. In both cases the flow formation is reduced considerably and the propeller must be replaced. The solids deflection ring must also be checked. If wear or scoring is visible on the propeller boss these parts must be replaced as well.
<b>MEASURE:</b>	If you find out any cases of the damage described above please contact your local Sulzer Service Centre.

<b>PERIOD OF TIME:</b>	<b>Recommendation: every 6 months</b>
<b>ACTIVITY:</b>	Insulation resistance check.
<b>DESCRIPTION:</b>	Within the scope of the maintenance work the insulation resistance of the motor winding should be measured every 4,000 hours, and/or at least once a year. If the proper insulation resistance level is not reached, moisture might have got into the motor.
<b>MEASURE:</b>	The unit must be taken out of operation and may not be started again. Please contact your local Sulzer Service Centre.
<b>ACTIVITY:</b>	Functional testing of the monitoring devices.
<b>DESCRIPTION:</b>	In the scope of the maintenance measures functional testing of all monitoring devices must be carried through every 4,000 hours and/or at least once a year. For these functional tests the unit must have cooled down to the ambient temperature. The electrical connecting line of the monitoring device must be disconnected at the control box. These measurements must be carried through by means of an ohm meter at the respective cable ends.
<b>MEASURE:</b>	In the case of any functional problems on the monitoring devices please contact your local Sulzer Service Centre.

<b>PERIOD OF TIME:</b>	<b>Recommendation: once a year</b>
<b>ACTIVITY:</b>	Checking of the tightening torques of the screws and nuts.
<b>DESCRIPTION:</b>	For safety reasons we recommend that all screws are checked for their perfect positioning once a year.
<b>MEASURE:</b>	Tighten screws with correct tightening torques (see 6.3).

1. Manufacturer:	Sulzer Pump Solutions Ireland Ltd. Clonard Road, Wexford, Ireland		
2. Year of production:	_____		
3. Serial no.:	_____		
4. Type:	_____		
5. Check before first operation:	on:		by:

**Recurring checks (at least once a year)**

Date	Remarks	Operating hours	Signature	Repaired on/by
------	---------	-----------------	-----------	----------------

**Recurring checks (at least once a year)**

<b>Date</b>	<b>Remarks</b>	<b>Operating hours</b>	<b>Signature</b>	<b>Repaired on/by</b>
-------------	----------------	----------------------------	------------------	---------------------------

