

Submersible drainage pump XJ 80

Specification

Electric submersible pump.
 Maximum submergence: 20 m. Protection class IP 68.
 Max temperature of pumped medium at max power input and continuous duty 40 °C.
 Max medium density 1100 kg/m³. pH of the pumped medium 5-8.
 Strainer hole: 7.5 x 22 mm. Max number of starts 30/hour.

XJ 80 ND	Medium head, 3-phase
XJ 80 ND AT*	Medium head, 3-phase
XJ 80 LD	High flow, 3-phase
XJ 80 LD AT*	High flow, 3-phase
XJ 80 SD	High head, 3-phase
XJ 80 SD AT*	High head, 3-phase

*AquaTronic: Built-in electronic pump control.

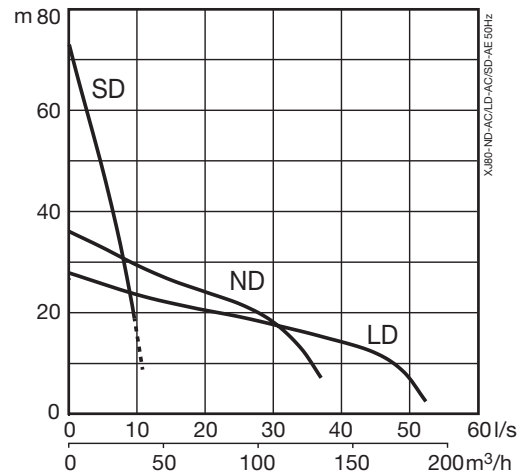

Electric motor

3-phase squirrel-cage induction motor, 50 Hz.
 Service factor 1.1. Class F insulation.
 Motor rating P2: 8.3 kW. 2 pol. Speed: 2920 rpm.
 η : 89.9 (50 %), 90.6 (75 %), 89.6 (100 % load)

Voltage, V	230	400	500-550	690	1000
Nominal current, A	27.8	32	13.8	9.3	6.4

Starting method and motor protection

XJ 80 AT: Direct on line start (DOL 500-550 V) with built in AquaTronic unit, which automatically adjusts phase order by dual contactors, ensuring correct motor rotation. Soft start (230-400 V) is built in with the AquaTronic unit, where three thyristors reduces start current to three times the nominal current. Here two relays ensures correct motor rotation.

The AquaTronic unit monitors motor temperature, by use of NTC thermistors built into stator windings, and stops the motor at high temperature. It will also stop the motor at high amperage or if a phase is missing.

XJ 80: Direct on line start with built in contactor. Pumps to be used with VFD or 1000 V must have terminal block instead of contactor. Thermal switches (140 °C, ± 5) built into the stator windings are connected to the contactor and stop the pump at high temperature.

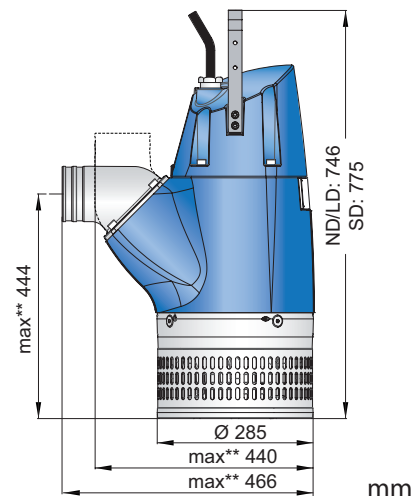

** Max measurement based on largest discharge size.

Power Cable

20 m type H07RN8-F (standard cable):

- 4 x 4 sq.mm. (230 V)
- 4 x 2.5 sq.mm. (400-550 V)
- 4 x 1.5 sq.mm. (690 V)

20 m type NSSHÖU.../3E (heavy duty cable):

- 3x2.5+3x2.5/3E+3x1.5 (3 control cables included) (1000 V or terminal block)
- 3x6+3x6/3E+3x1.5 (230 V)
- 3x2.5+3x2.5/3E (400-550 V)
- 3x1.5+3x1.5/3E (690 V)

Shaft Seal

Double mechanical seal in oil bath.
 Primary seal: Silicon carbide on silicon carbide.
 Secondary seal: Silicon carbide on carbon.

Bearings

Upper bearing: Single-row deep groove ball bearing.
 Lower bearing: Double angular contact ball bearing.

Discharge connections

3" (standard SD), 4" (standard ND), 6" (standard LD)
 hose connections.
 3", 4", 6" G/B.S.P. threaded connections.

Weight

ND/LD: 63 kg, SD: 78 kg (without cable)

Options and accessories

AquaPlug. AquaTronic control panel. Level sensor. Service data kit. Zinc anodes. Surface protection coating. Series connection. Floatation system. Discharge connection accessories and hose.

Pump control

Features	XJ 80	XJ 80 AT			Service Data Kit Read out	
		AT	AT+ Level Sensor	AT + AquaPlug / AquaTronic Control Panel		AT + AquaPlug / AquaTronic Control Panel + Level Sensor
Run mode	●	●	●	●	●	-
Integrated start equipment	●	●	●	●	●	-
Automatic direction of rotation	-	●	●	●	●	-
Motor protection high temp	●	●	●	●	●	●
Motor protection high amp	-	●	●	●	●	●
Protection against missing phase	-	●	●	●	●	●
Level control	-	-	●	-	●	-
Dry run protection	-	-	●	-	●	-
Automatic restarting	-	-	●	-	●	-
Stop mode	-	-	-	●	●	-
E-mode (Automatic stop/run)	-	-	●	-	●	-
Indication of water in oil	-	-	-	●	●	●
Indication of low motor insulation	-	-	-	●	●	●
Indication of high or low voltage	-	-	-	●●	●●	●
Indication of high temperature	-	-	-	●●	●●	●
Indication of high amp	-	-	-	●●	●●	●
Indication of phase unbalance	-	-	-	●●	●●	●
USB cable connection	-	●	●	●	●	●
Crash log (10 latest)	-	-	-	-	-	●
Documentation (spare part list, workshop manual)	-	-	-	-	-	●

●● = Fault indication when pump is automatically stopped to protect the motor.

Materials

Description	Material	EN	ASTM
Castings	Aluminium	EN 1706:AC-43100	ASTM A1Si10mg
Strainer / Handle	Stainless steel	10088:X5CrNi18-10 (1.4301)	AISI 304
Rotor shaft	Stainless steel	10088:X20Cr13 (1.4021)	AISI 420
Impeller / Wear ring	White cast iron	EN-GJN-HV600(XCr23)	ASTM A 532: Alloy III A
Fasteners	Stainless steel	10088:X5CrNiMo 17122 (1.4401)	AISI 316
Wear parts / O-rings	Nitrile rubber		
Coating	2 component epoxy paint 120 µm		

[sulzer.com](https://www.sulzer.com)

XJ 80 50Hz EN (06.2024), Copyright © Sulzer Ltd 2024

This document does not provide a warranty or guarantee of any kind. Please contact us for a description of the warranties and guarantees offered with our products. Directions for use and safety will be given separately. All information herein is subject to change without notice.