

## ABS APC UP TO 1 Ó 2 PUMPS CONTROL PANEL BY SULZER PUMPS WASTEWATER SPAIN, S. A.

### USER GUIDE



---

**1. CONTENTS**

---

**1. CONTENTS****2. GENERAL DESCRIPTION****2.1 PREVIOUS COMMENTS****2.2 SAFETY RULES TO CONSIDER****2.3 SCOPE. DEVICES AND FEATURES (ENCLOSURE AND POWER EQUIPMENTS)****2.4 SCOPE. DEVICES AND FEATURES (CONTROL CIRCUITS AND EQUIPMENTS)****2.5 INSTALLATION RECOMMENDATIONS****2.6 CONTROL SYSTEM DESCRIPTION****3. OPERATION****3.1 AUTOMATIC SEQUENCES****3.2 SAFETY FACTORS****4. RECOMMENDED DOCUMENTS FOR READING****4.1 ELECTRICAL DRAWING****4.2 4.2 FORM TO REGISTER PC242 SETTINGS****4.3 USER GUIDES FOR DEVICES RELATED TO APC CONTROL PANELS**

- A. LEVEL SENSORS MD124 / MD126 / MD127: USER AND INSTALLATION GUIDE
- B. PC242 PUMPS CONTROLLER INSTALLATION GUIDE
- C. PC242 PUMPS CONTROLLER USER GUIDE
- D. PC242 PUMPS CONTROLLER COMLI/MODBUS REGISTER GUIDE

**5. DECLARATION CONFORMITY**

---

## **2. GENERAL DESCRIPTION**

---

Control panel designed to protect, monitor, run and control in pump pit stations up to 2 pumps, allowing a later connection of the control panel to a remote system via SCADA AquaVision or similar or over Internet (Web Server AquaWeb).

---

### **2.1. PREVIOUS COMMENTS**

---

The main power supply must be 400V 3~ / 50Hz (type 3 PH + E, neutral pole is not necessary) and have to be connected in clock sequence on terminal R, S y T as is shown in the electrical diagrams.

Before its first use, make sure that all screw connections are properly done. For power connections you must use a torque wrench (follow the tool instructions to obtain a correct torque).

---

### **2.2. SAFETY RULES TO CONSIDER**

---

**WARNING!**

**You might not get into the control panel while it has voltage inside (connected to the electrical net) under any circumstances. Before doing it, make sure the control panel is completely disconnected.**

**WARNING! ELECTRICAL HAZARD INSIDE**

**YOU HAVE TO DISCONNECT THE MAIN SWITCH BEFORE MAKING ANY TASK INSIDE THE CONTROL PANEL (CABLE CONNECTION, REPARATION...)**

We recommend you to contact to an authorized specialist company to install the control panel and connect the cables, its personnel must know and follow the electrical rules (technically and regarding safety) and recommendations.

To avoid losing the warranty, only Sulzer Pumps Wastewater specialist technicians can manage and modify the control panel or, at least have to support any of this kind of works. Contact to Sulzer Pumps Wastewater Spain if you need support (+34 916 702 851).

Avoid to open the control panel door with voltage inside it, before to open the door make sure the main voltage supply is not present or, at least make sure that the main switch is disconnected (what means the control panel only could have voltage at the power input from the electrical net).

---

**2.3. SCOPE. DEVICES AND FEATURES (ENCLOSURE AND POWER EQUIPMENTS)**

---

- Metallic enclosure IP54 after pilot installation.
- Three phase main switch (AC21) with door handle allowing disconnecting voltage supply from outside before to open the control panel door.
- Motor circuit breaker to every pump power output. MCB used in APC have thermal trip regulation according to the pump power load.
- Earth leakage switch to every pump power output. For pumps smaller than 38 Amps motor consumption, these earth leakage switches have a fixed trip point at 0,3 Amps.
- Available with DOL, START-DELTA, Soft Starter and VFD as a method to run the motor.

---

**2.4. SCOPE. DEVICES AND FEATURES (CONTROL CIRCUITS AND EQUIPMENTS)**

---

- Advanced control system with graphic display ABS PC 242, door mounted to allow an easy setting up and use of the system.
- Ready to work with analogue sensors (0-20 or 4-20mA) or floats. Normally you will receive an offer of an APC version that includes devices for level measurement or level floats (as required).
- Door mounted selectors to run manually each pump (with no relation of what PC 242 does)
- Emergency control circuit that works over the PC 242 in case of failure of the level normal measurement system, in APC basic version; and made by relays, allowing working even if PC 242 were broken down, in APC complete version.
- Ready to receive a thermal sensor signal from each pump, that could be bimetallic type, PTC or PT100. PC 242 has an internal module to manage PTC and PT100 signals built in, what allows to indicating the current temperature the sensor measures, and set alarm set points.
- Ready to receive a leakage sensor signal from each pump. PC 242 has an internal signal conditioner for ABS leakage signals built in, what allows to monitor the pump state and set alarms.
- Digital voltmeter door mounted
- Electronic amp meter built in PC 242 to monitor puma status and set alarms (only available in complete version of APC).
- General reset push button.
- Synoptic to show how the pump pit works, with LED pilots to see what pumps are running and if the high level float is activated. This synoptic incorporates the selectors to choose the pump mode operation (MANual-0-AUTOMATIC), and another selector that allows choosing pumps that will work with the emergency control system (last selector only available in complete versions of APC).
- Indication of general alarm, pump 1 alarm and pump 2 alarm, via 3 dry contacts
- SELV control circuit type, with 24Vdc to feed controller, sensor, floats, pump signals,...
- With two RS232 serial ports. One of them to connect directly a computer using a DB9 standard plug for service; and the other for direct/radio/GSM/GPRS/OpticFiber/... communication, connecting the modem to PC 242 terminals.

**2.5. INSTALLATION RECOMMENDATIONS**

To make easier the job each terminal clamp for pump cable is named equal than the correspondent pump cable, and the other cables are named considering their function. Due that:

1. As it is shown in the power connection page of the electrical diagram, you have to connect main cables in clock sequence in terminals R, S, T and PE (neutral pole is not necessary).
2. As it is shown in the power connection page of the electrical diagram, Pump 1 power cables named as U1, V1, W1 and PE have to be connected in terminal clamps B1:U1, B1:V1, B1:W1 and PE. Pump 2 power cables named as U1, V1, W1 y PE have to be connected in terminal clamps B2:U1, B2:V1, B2:W1 and PE. If starting method were delta-star, we will add U2, V2 y W2 to those indications.  
In case you had to connect a motor wired for delta-star starting method in a control panel where the way to run the pump were DOL, soft starters or VFDs, you would be able to make the delta connection over the control panel power terminal clamps connecting cables U1 and W2 in terminal clamp U1, cables V1 and U2 in terminal clamp V1, and cables W1 and V2 in terminal clamp W1 (of course PE cable to PE terminal clamp).
3. Same way you could see that thermal signal cables from pumps (named F0 and F1) must be connected in terminal clamps Bn:F0 and Bn:F1; and leakage signal cables from pumps (named DI and PE) must be connected in terminal clamps Bn:DI and Bn:PE. Some small pumps have power and signal wires in the same cable, in that case you will not have a PE cable for power and other for signals; nothing will happen if you remember to connect properly the PE power cable to the PE power terminal clamp, and connect the signal terminal clamp B1:PE to one of the control panel earth connections. **In case of pump without bimetallic thermal sensor you should remind to make a direct connection between terminal clamps Bn:F0 and Bn:F1 for this signal, if you do not do it pump will never run.**

**Read and follow the measurement device user guide before to install it and connect it to the control panel,** mainly regarding safety recommendations and indications about a proper installation.

There are pump pits that have an inlet where connect a pneumatic sensor. Some kind of pre-fabricated sumps made by ABS have a T racor installed to use with this kind of sensors and an air compressor.

As is shown in the right side picture, when connecting the air pipe included in the scope of the APC control panel with MD 124 pneumatic sensor, replace this T racor and connect directly the racor included in the supply (only when less than 10 m pipe).

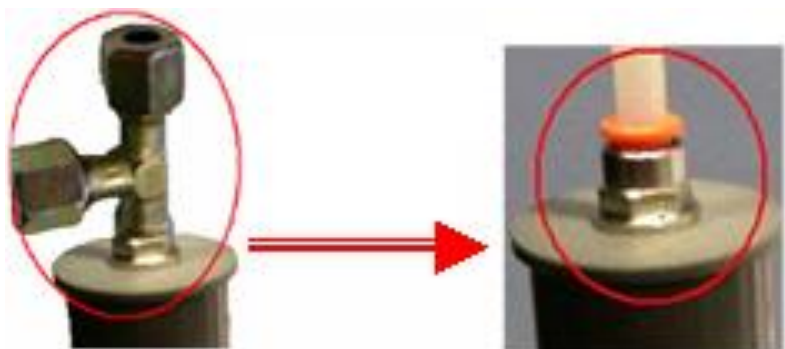

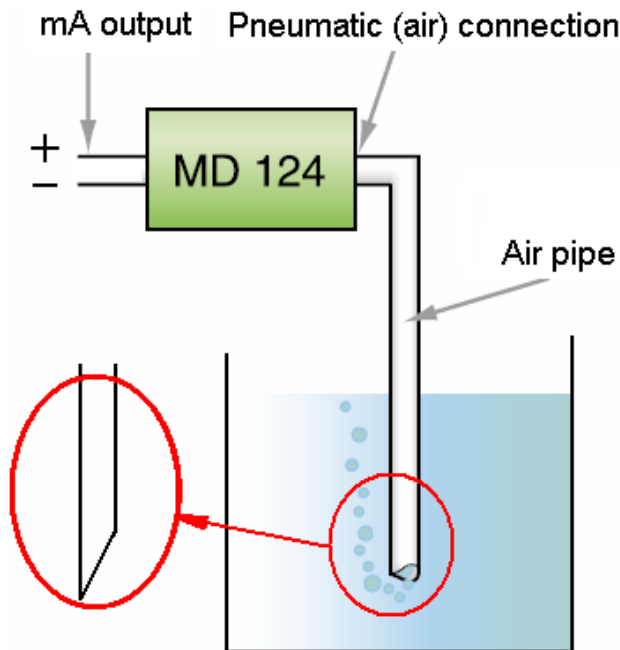

You have to consider that the **majority of the mistakes using a pneumatic sensor usually happen due to pipe clogging or due to air losses in the pipe or/and pipe junctions**; if you are going to use a pre-fabricated sump made by ABS without this inlet and with an APC control panel with MD 124 pneumatic sensor, make sure to avoid pipe clogging as making a diagonal cut to the air pipe to have a bigger area of the side of the pipe submersed (as it is shown at the left side picture).

When using an hydrostatic level sensor you must consider effects that could appear when installing the sensor hung from the pump pit top; turbulences could make it hit itself with the sump walls or making a pendular movement that will could wear sensor housing due friction; it even could be as close to the pumps inlet that they could be able to suck up the sensor. You have to choose the best way to install the sensor considering the turbulences are supposed to appear, effect of the pump hydraulic inlets... The right side picture shows some ways to install this kind of sensors. No matter the way chosen, **make sure to install the sensor avoiding the pumps were able to suck it up, and avoiding the sensor were moving with friction against a wall or hitting it; if not, the sensor could be damaged till break down.**

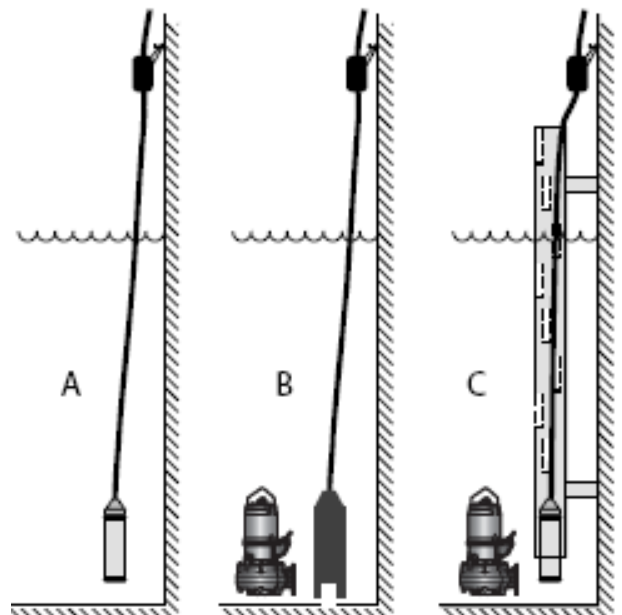

**When using an analogue sensor (hydrostatic, ultrasonic...), remember to connect properly the cable's shield to the control panel ground to avoid noises and disturbances in the measurement signal.** Settings in PC 242 when it is mounted in an ABS APC control panel include a time filter for this input signal, if were needed you could increase the default pre-set time filter setting.

## 2.6. CONTROL SYSTEM DESCRIPTION

The bellow picture shows the control panel's synoptic; where it's shown there is a selector for each pump to choose the way it has to work. We could choose between make the pump run manually (MAN), automatically (AUTO) or make it be disconnected (0):



### MANUAL OPERATION (SELECTOR IN "MAN")

Moving mode of operation selector to MAN, pump will start and continues running without any consideration to level signals, PC 242 setting of max number of pumps allowed to run at the same time, etc... While in MAN, pump will only stop if the MCB, the earth leakage switch or the thermal sensor were tripped (or in case of motor drive failure).

It is thought mainly for tests during the pump station setting up and maintenance pump checks. For safety reason it returns automatically to 0, you have to keep activating the selector for the period of time you want to retain the pump running (avoiding to burn the motor by accident).

### PUMP DISABLE (SELECTOR IN "0")

In this position the pump control wire is cut, letting the pump disabled to run in automatic, manual or with the emergency control circuit (semiautomatic). **Don't forget also to disconnect and to block the MCB before any maintenance actuation**, avoiding taking mechanical or electrical risks (a contactor could have a shortcut, a VFD or a soft starter could present electrical current leakages, etc...).

### **AUTOMATIC OPERATION (SELECTOR IN “AUTO”)**

Moving mode of operation selector to AUTO, PC 242 will run the pumps: level where start, level where stop, delays between starting and stopping pumps, alternation, status indication (running hours, starts counter, pump capacity and in/out-flow calculations...); alarm management with date and time stamp for every alarm and event.



Thanks to PC 242 you even can run the pump manually activating it via the keyboard of the controller, or in remote mode via communications. If you start the pump manually via PC242 keyboard it will continue pumping till stop level (or level float); if level where not over stop level set (or level float) when you run the pump manually via PC242 keyboard PC 242 will only give a short start pulse.

For more info read the section “AUTOMATIC SEQUENCES”, the PC 242 user and installation guides, and the document named “SETTINGS IN CONTROL PANEL MODEL APC2B COMPLETE PROGRAMMED FOR USING WITH LEVEL FLOATS” specific for this project.

### **SEMI-AUTOMATIC OPERATION (SELECTOR IN “AUTO”)**

APC control panel basic version has a semi-automatic control system based on a PC 242 feature that runs the pumps if the high level float gets active, what could happen in case of failure of the level measurement devices. The semi-automatic control system of an APC control panel complete version is not based on a PC 242 feature because it works with an external relays circuit, what allows the system to control pumps with the high level float signal, even if the controller were broken.

There is a selector in an APC control panel complete version that allows us to choose which pumps will work in the semi-auto control. Anyway, if the pump mode of operation selector is not in AUTO mode, the semi-auto system will not work with this pump.

For safety reasons, the semi-auto system will never work with a pump which mode of operation selector was set to 0.



---

### 3. OPERATION

---

The work of any Sulzer Pumps Wastewater Spain control panel pursues the best pump pit station operation and reliability with lowest energy and maintenance costs. Other designs aspects pursue avoid labour and equipment accidents, not allowing manual operation if the operator doesn't keep in front of the panel, allowing the complete disconnection of the control panel from outside, etc.

---

#### 3.1. AUTOMATIC SEQUENCES

---

A standard APC control panel works, by default, as follow.

The main task is the pumps operation related to levels. We can set a couple of start-stop normal levels for each pumps (or floats in case of operation with them). When the APC works with floats, the start and stop levels are tied to the place where the floats switch on and off; when works with level sensor, those levels can be set from the controller display (or in remote).

There is as an APC control panel option, to upgrade control and protections for an auxiliary device related to the pit like a mixer, drain pump, valve, or a cleaner system.

The PC 242 user and installation guides and the document named "SETTINGS IN CONTROL PANEL MODEL APC2B COMPLETE PROGRAMMED FOR USING WITH LEVEL FLOATS" specific for this project, show in detail how **PC 242 controls and monitors pumps and pump pit in an advanced way**. Summarizing we can say that:

- With normal operation, when the first start level is reached (or in case of first start float activation) first puma will start, when second start level is reached (or in case of second start float activation) second pump will start. We can set different stop levels, but if we set same stop level for all pumps (or working with floats, because can only connect one common stop level float to the unit), they will stop with a delay between stops. See PC 242 user guide and the document named "SETTINGS IN CONTROL PANEL MODEL APC2B COMPLETE PROGRAMMED FOR USING WITH LEVEL FLOATS" specific for this project, for more details or to learn how to change related settings.
- Both starts and stops are done with a **delay in between** to avoid more than two or more pumps were started (or stopped) at the same time if max number of pumps allowed to run is set over 1. This way we avoid electric troubles (high current loads on pump starting) and water-hammer. If you deactivate alternation and set max number of pumps allowed to run to 1, PC 242 will allow you to set the priority of the pump that must run to the pump with the highest start level.
- APC can work both with level floats as analogue level sensors. Analogue level sensor allows taking advantage of the PC242 advanced pump controller). We recommend to use a submersible hydrostatic level sensor like ABS MD125, MD126, MD127 and HSC2, with a stainless steel enclosure and a ceramic sensor element, instead of less robust devices or non-intrusive sensors (like ultrasonic measuring devices) to avoid condensation, bounce signals on walls, foam effect, etc. things that cause measurement errors and problems in the own sensor; at the same time allowing an easier and cheaper maintenance, great robustness and reliability, etc. Pneumatic analogue level sensors like ABS MD124 are cheap, giving some of the advantages of a submersible sensor with the drawback that only must be used when were not supposed any risk of the air pipe clogging.

After high level float activation system warns with the proper alarm and a semi-automatic control way of run pumps is activated too, starting pumps available at that moment till this float deactivation. This signal will even acknowledge all alarms not acknowledged in the controller, unblocking pumps that could be blocked due false alarms.

- PC 242 enables advanced management of pumping "INPUT FLOW CALCULATION". Based on level measurement and analogue sensor data entered into during the launch of the volume of the well, the system accurately calculates the flow rate into the well when the pumps are stopped. It is very difficult to implement this feature when the water inlet manifold is at levels close to the bottom of the well.

- PC 242 enables advanced management of pumping "CALCULATING THE CAPACITY OF BOMBS". Based on the input flow and knowing that does not change abruptly whenever one starts a pump, PC 242 estimated pumping capacity running an advanced calculation algorithm based on interpolation between input and output flows.

- PC 242 enables advanced management of pumping "OUT FLOW CALCULATION". Based on the calculated value for the pumping capacity of each pump, PC 242 can meet the outflow both when only one pump is running, as when several work at once (using a correction factor of pumps in parallel).

- PC 242 enables advanced management of pumping "DYNAMIC MONITORING WELL". Thanks to its colour LCD graphic display, PC 242 displayed dynamically and numerical levels, consumption of pumps and pumping flow rates as well as numerically the pump status, alarm signals, historical operating and alarms, etc. Connect the signal cables box of each pump and level measuring element to make better use and management of pump alarms and in this way work with PC 242 pump vital signs (temperature sensors and humidity, state motor protection circuit breaker, motor consumption or contactor activation confirmation gear pumps) and pump (level sensor and / or operating buoys and buoy alarm). In standard execution level sensor allows monitoring APC1/2B level, flow, and consumption in amps, to include power module option: active, reactive and apparent power, power factor loads, mains voltage, etc.. PC 242 also allows you to trend graphs level curves, consumption and flow pumping.

- PC 242 enables advanced management of start and stop pumping before abrupt change in level, function known as "START EARLY IN CASE OF STORM". It is able to start the pumps in advance to avoid overflows in the well if it detects sudden changes in level. In rainwater pumps and pumping sewage mixed is easier than to start a storm wells filling up the dimensions will start pumping when the bombs begin to start flooding these wells are finished without a good relationship between storage volume and pump capacity and collector wells receiving water from other pumps. Start function level to abrupt change allows to anticipate this situation and start the pumps prior to reaching the normal working levels (if the level is above the elevation of unemployment), so that the water will start to evacuate beforehand, preventing overflow and laminating the water inlet to the treatment plant.

- PC 242 enables advanced management of pumping up doing short cycles, even without water in the well, to exercise each pump after long periods without this has worked, such a manoeuvre between 1 and 10 seconds after 2 or Stop 5 days, depending on the type of fluid in which the pump is submerged, and the model and power of the same. It is highly recommended to use this "FEATURE PUMP EXERCISE" also known as "DRY SEASON START" mainly in storm water pumping so as to avoid blocking the pump shaft by oxidation.

- PC 242 Advanced manages pumping with "RANDOM STRIP DIMENSIONS REFERRED TO RUN". From the PC 242 user interface for each pump adjust band randomly around the dimension you've set for March, so that the pump starts randomly when the level is in the range of dimensions defined by the height of up + / - random band said. The feature is only available to work with analogue level sensor, not buoys, and is useful for preventing the formation of crust (and the resulting odours) regrowth on the walls of the well at elevation where the first bomb usually tear.

- The operation of the equipment has advanced alternation PC 242. "ALTERNATION NORMAL" or run command is not always be the same pump the boot when reaching a certain height, but in each case is different pump (pump obviously that starts at an elevation of Bn stop at elevation set as stop Bn). Advanced Alternating provides advantages as "ALTERNATE TO BOMB LOCKED": If the pump is blocked by alarm (alarm including lack of confirmation of operation) or its operating mode selector is set to 0, PC 242 leaves the pump off service and alternative to other pump is available, "ALTERNATION EXCESS LONG RUN": to set a maximum time of travel, after which the pump and performs alternating yet have reached its height stop, avoiding jams, "ALTERNATION ASYMMETRIC": set a different number of starts for a pump configured on a main group defined as starting a pump each secondary group.

- PC 242 enables advanced management of pumping "DISCRIMINATION OF SLOTS". With this feature you can define different time slots for each day of the week, so that in times of reduced inflow we adjust some levels to start and stop the pumps to work in the highest area of the well (pumping more caudal less consumption), so you save energy by improving the performance and reducing working hours (in addition to extending the life of the pump). Also allows us to make emptying the pit to levels even lower than the normal stop before passing the stretch of arrival peak hour flow in order to avoid overflows.

- PC 242 allows "REMOTE CONTROL AND PROTECTION OF AUXILIARY EQUIPMENT (SHAKER)" it has integrated functions associated with the operation of pumps, control a shaker, cleaning system, or bilge pump. Delivered default programmed to control a shaker, so that each pump 5 starts operating during the first 30s of the pump. No agitator includes manoeuvring the semiautomatic control system, because when said control system is activated, the performance of a stirrer may cause problems due to excess consumption for pumping. Procured this optional extension, the table will include:

1. Electrical protection: MCCB circuit breaker (throttle curve with adjustable sensitivity), and industrial application circuit breaker (4P25A/300mA)
2. Contactor for direct start.
3. Relays and control for manual or automatic control with PC 242.
4. Humidity module DI and where would rank synoptic selector mode (manual, automatic or off), and signalling pilots shaker states: thermal and moisture probes, motor protection circuit breaker and motor running.

---

**3.2. SAFETY FACTORS**

---

**It is very important to correctly connect the signals from temperature and humidity sensors of each pump to monitor its state. There are three free of potential contacts in the control panel: one alarm from each pump and alarm status to be reset on the controller.**

**Remember to disconnect and lock every protection, motor circuit breaker and/or earth switch before any maintenance action.**

**ALARM RESET**

Any new alarm can be reset individually by the controller user interface also available at the door of a button box with emergency you can reset all alarms at once. For security reasons pumping operation, the activation level alarm float, well signposted in the box and the display of PC 242, causes a safety reset all reset alarms that they had in PC 242, unlocked so that if the pumps automatically be blocked.

**LOW LEVEL ALARM**

If you use an APC box with analogue level sensor, and also shows the sump level in real time via the display in both graphical and numerical mode, PC 242 allows you to generate alarms activating level and potential free contact failure usually when they occur. If the active and the level drops for at least 10s of the value set for low level alarm, the controller will alarm with the text "Low". Usually the low level alarm pumps only used for filling tanks or pumping catchment, so that by default the APC box comes with this feature disabled, if interested activate follow the user manual PC 242 and / or implementation guide APC 2B frame.

**HIGH LEVEL ALARM**

If you use an APC box with analogue level sensor, and also shows the sump level in real time via the display in both graphical and numerical mode, PC 242 allows you to generate alarms activating level and potential free contact failure usually when they occur. Reached or exceeded for at least 5s alarm level set to high, the controller generates an alarm with the text "high level". By default we deliver pictures with a value for this alarm is adjusted according to the size of the pumping equipment which are manufactured, if you need to adjust to an optimum value for pumping well follow the user manual PC 242 and / or implementation guide APC 2B frame.

**HIGH LEVEL FLOAT ALARM**

Table APC has a signal input for a high level switch to activate the semiautomatic control system to generate alarm level (either for high level alarm drain wells). When the signal is received, the controller indicates the alarm on the operator panel with the text "high float" and activate the floating contact general fault. You must install this buoy above the height adjusted to high level alarm, becoming an extra-alarm high level above that of said buoy and allowing the system to generate an alarm before reaching semiautomatic control act. For safety is done automatically reset all alarms reset brought forward in PC 242 when activating the alarm float.

**OVERFLOW LEVEL ALARM**

If you use an APC box with analogue level sensor, and also shows the sump level in real time via the display in both graphical and numerical mode, PC 242 allows you to generate alarms activating level and potential free contact failure usually when they occur. Reached or exceeded for at least 5s alarm level set to overflow level, the controller will alarm with the text "overflow". By default we deliver pictures with a value for this alarm is adjusted according to the size of the pumping equipment which are manufactured, if you need to adjust to an optimum value for pumping well follow the user manual PC 242 and / or implementation guide APC 2B frame ".

**PUMPPIT IN AND OUT FLOW AND PUMP CAPACITY CALCULATONS**

PC 242 is constantly calculating the flows into and out the well and pump capacities. Thanks to which we can tell the controller to a minimum value of each pump capacity, so that if the calculated value is greater than or equal to that value, to let us know and past 10s PC 242 will create an alarm using the alarm text "Capac. low pumping Bn "and activate the floating contact general fault. This alarm not only the pump is indicated to help save energy and optimize pumping it with a review of the pump could save energy and / or avoid major faults. Similarly, we can specify a maximum flow rate into the well, so to overcome, PC 242 10s directed past the alarm text "Inflow high" and activate the floating contact general fault. This alarm also for pumps and also signalled only helps the user.

**PUMP NOT IN AUTO (NOT AVAILABLE)**

Each pump has a switch "MAN-AUT-0" in front of the box to set the operating mode in which we work. If after handling is left in position "0", the pump is out of service. To avoid this, if after 60s the selector is not passed to "AUTO", PC 242 advised of this fact by an alarm text "not in Bn Pump Auto" and activate the floating contact general fault. This alarm is not for the pump, only signals to help prevent flooding in case of neglect, failure selector or otherwise.

**ALTERNATION IN CASE OF PUMP BLOCKAGES**

In either blocked pump alarm for not being serious or selector "MAN-AUT-0" in the "AUT", PC 242 activated with their journeys to the next by alternation. Serious alarm can be confirmed not running, tripping of the circuit breaker or thermal probe.

**LEAKAGE ELECTRODE IN PUMP FOR MONITORING**

Some pumps have electrodes to detect the presence of water in areas of the pump where there should be none. Many pumps ABS feature a moisture called DI electrode to detect the presence of moisture in the oil chamber (or security camera pre-cooling chamber), other electrodes also feature DI in the motor or the connection compartment. APC Table is ready to receive the signal directly electrode pumps ABS / Flygt without requiring buffer amplifier (known as DI module). For adequate protection and monitoring connect these sensors to the frame correctly. In case of alarm PC 242 will not stop the bomb, but indicate the alarm status by the text "Bn pump oil leaks" also marked by floating contact general fault. IF THE PUMP IS NOT PROBE HUMIDITY, LEAVE WITHOUT CONNECTING TERMINALS FOR SUCH ITEM PICTURE.

**TEMPERATURE ELECTRODES IN PUMP FOR MONITORING**

Some pumps have thermal sensors in areas with higher warming trend, as the motor winding and the upper and lower bearings. As standard the APC box 1/2B is ready to receive a temperature signal for pump bimetal type (in case of PTC or PT100 should add a module temperature monitoring CA442 optional). For adequate protection and monitoring, these sensors must be properly connected to the box. If pump heating thermistor is activated bimetallic APC box stops the pump instant both manually, or semi-automatic through the control line of the picture; alarm indicating the PC 242 via the text alarm "High temperature pump Bn" and is marked by floating contact general fault, plus alternating activated PC 242 from pump failure launching the next bomb touched by alternating cycle. Any APC considers that after a pump stop alarm temperature sensor, usually the pump will cool faster because it has stopped and is submerged, so keep it locked up driver alarm reset, after which the reenters pump service. **Be sure to connect the terminals shorted box for connection of the temperature sensor for each pump or auxiliary equipment that does not have such a signal, otherwise controller will never start the pump.**

**MCB AND EARTH PROTECTION SWITCH FOR EACH POWER OUTPUT TO PUMP**

A picture APC protects each motor output through a curved magnetic protection switch motor (with adjustable sensitivity thermal trip) and a differential protection switch for industrial (300mA sensitivity and instantaneous trip).

Instead of using general differential protection frame header, used motor output protection to ensure the availability of pumps in pumping, since in case of tripping earth leakage current in a pump or the feed cable, or against nuisance tripping on start, would act only protecting the pump leaving the rest available (thus differential protection is especially important in pumping rainwater).

Fully finished in APCs, is connected to a digital input signal PC 242 combined for each set of magneto-differential switches so that in case of fire, the controller instructed with the text "pump motor Prot Bn Shot" and signalled by potential free contact general fault. From the alarm was raised, the pump is de-energized it, stop giving PC 242 running order and cut his line of command in the box, but not locked, so that once manually reset the pump protection come back into service even if not reset the alarm, should be so has acted on the protection manually, plus alternating activated PC 242 from pump failure.

**MOTOR CURRENT CONSUMPTION**

We monitor motor current consumption of each pump in an APC Fully finished using a current transformer as special (with type 4-20mA output) per pump connected to the PC for 242 analogue input (or signal control equipment when motor soft starters or variable frequency). This allows us to generate alarms for both high consumption value as reduced respectively marked as "High consumption Bn pump" and "Reduced consumption Bn bomb" on the display of PC 242, and in both cases by floating contact failure overall picture. This alarm does not cause stopping of the pump, so it can be used as a method to detect a possible shot at the time of the circuit breaker for pump power curve that has the APC box, so this should be set to alarm activated before the trigger point at which the circuit breaker is set.

**PUMP RUNNING CONFIRMATION**

In pictures APC finish up basic confirmation of each pump is by a signal from the motor control unit (DOL contactor, star-delta starter, soft starter or inverter) connected to a digital input of PC 242 . In APC Fully finished paintings used as current consumption of each pump for up confirmation thereof. In the start-up settings for each model indicate a threshold engine for lower power consumption to reduced power alarm, in this way for over 30s if not measured a consumption equal to or greater than said threshold value, PC 242 means that the pump is not working properly and stop. This alarm is indicated on the operator panel with text "Alarm No conf. Bn bomb "and is marked by floating contact general fault. When this occurs, PC 242 for the pump and keeps it locked automatically until the alarm reset (after which re-enters service) activates further alternating from pump failure launching the next pump cycle touched by alternation. This function protects the pump against various scenarios: empty working power failure, failure of motor control element, a driver may drop, etc

**CRITIC ALARM: ALL PUMPS BLOCKED**

If a pump is blocked by PC242 (due to an alarm or switch "MAN-AUT-0" to 0) and for some reason it blocks the other pump, pumping out of service will be completely automatic. To indicate this, after some time of 30s PC242 generate an alarm by the alarm text "B1 and B2 blocked". We can consider this alarm criticism for any pump not only is indicated to help prevent flooding by an oversight or otherwise

**COMMUNICATIONS, GSM-GPRS ALARM MANAGEMENT & SMS SENDS**

APC provides communications equipment and accessories that can be integrated into a network of telemetry via Modbus or Comli. If you request the table with GSM-GPRS modem, and data communication with the telemetry system (ABS AquaVision or similar) in its centrality or telemetry system using Web Server (AquaWeb or similar), the modem will allows sending SMS messages to mobile phones for alarm indication.

**SEMI-AUTOMATIC CONTROL SYSTEM INCLUDED IN BASIC VERSIONS OF APC**

With the mode selector of specific pump in position 0, the semi-automatic system will not act on the pump.

In pictures APC basic finish, PC242 is programmed to control the pumps with the buoy signal to sensor failure alarm, so the semiautomatic control system only works with component failure and also against controller failure.

## SEMI-AUTOMATIC CONTROL SYSTEM INCLUDED IN COMPLETE VERSIONS OF APC

With the mode selector of specific pump in position 0, the semi-automatic system will not act on the pump. In pictures APC Fully finished system is based on an external circuit to the controller which, when activated alarm buoy acts on ensuring the availability pumps pumping to sensor failure and even the driver.

For reasons electrical and / or hydraulic you may want to work on semi with only one pump. To make it easy, the APC Fully finished box has a handle on the door frame (called "SEMI COMPLETE APC") that allows you to indicate if you want this system to act only with the pump B1, B2 with the pump, or with both.

Once activated the alarm float pilot box excite alarm for warning buoy 2KA0 alarm and relay, starting the pumps enabled it, ie, those selected with the selector 2S4 (called "SEMI COMPLETE APC" ) and the operating mode selector to AUT. Pump In Tables 23A over 2TIM1 timer is used to prevent activation of both pumps. After the buoy off (which depends on the speed of emptying the well, one's hysteresis action of the buoy, the free cable length, the weight placement location, or that is connected to a buoy stop function only for semi-automatic control system) pumps stop.

For APCs with soft starters, you can also use a float stop for semi-automated system that allows you to bring more hysteresis between starting and stopping the system.

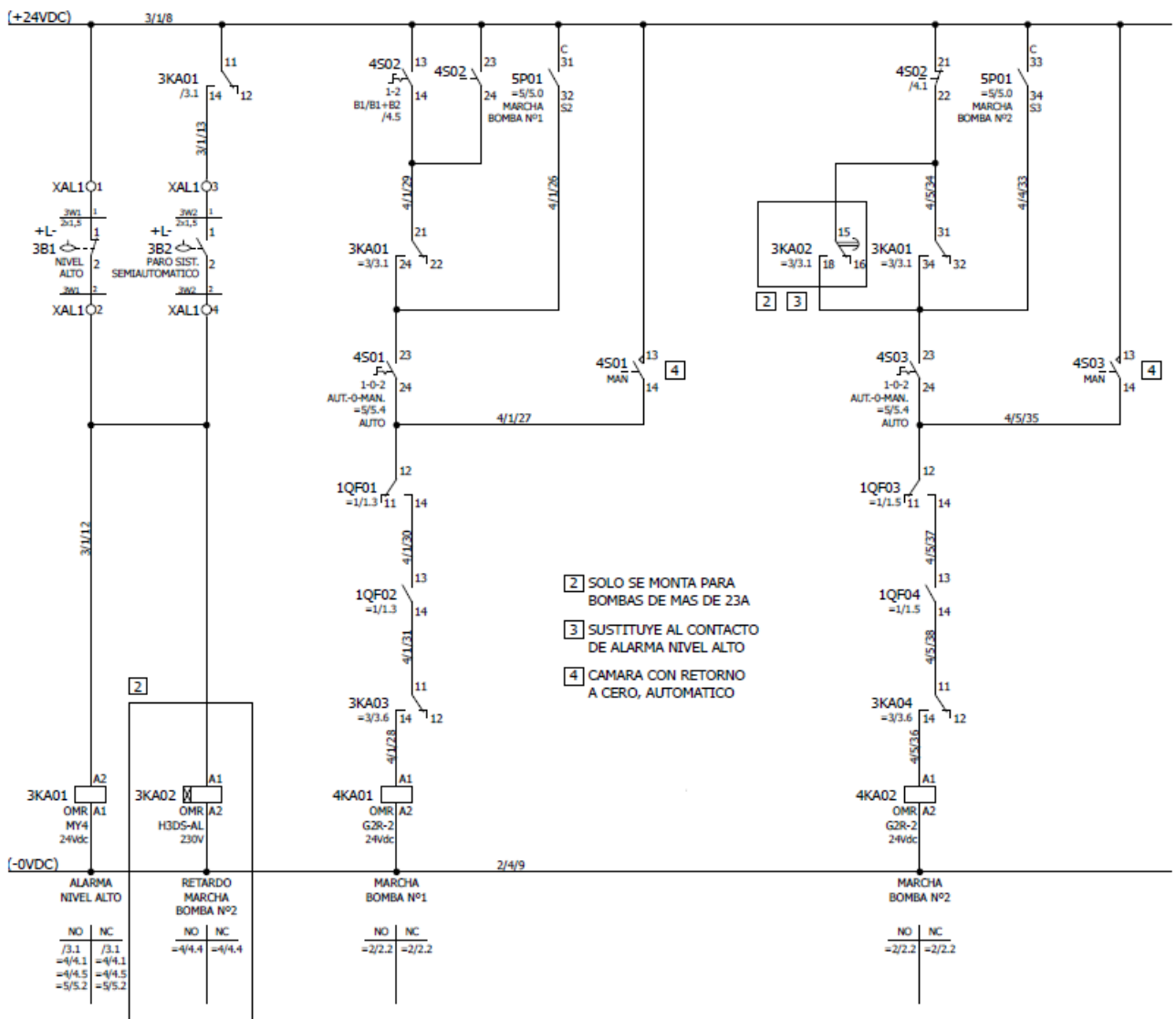



**ALARM SIGNALING AND PUMPS/PIT STATES SHOWN IN THE CONTROL PANEL**

Activating the alarm float and motor control element of each pump are indicated by pilots in the diagram of the well in the cabinet door.

Any alarms that occur in the system (pumps, well, sensor, etc..) And detect PC 242 is indicated in the user interface of the controller with the corresponding alarm text and, if reset pending, is also signalled by activation of a potential free contact for general alarm (AL box terminals: 3 to AL: 5). Thus a picture 1/2B APC has 3 potential free contacts for remote signalling: 1 alarm per pump and 1 to indicate that PC 242 has an alarm / s pending reset. This can be seen easily in the extract of the wiring diagram in the following figure.

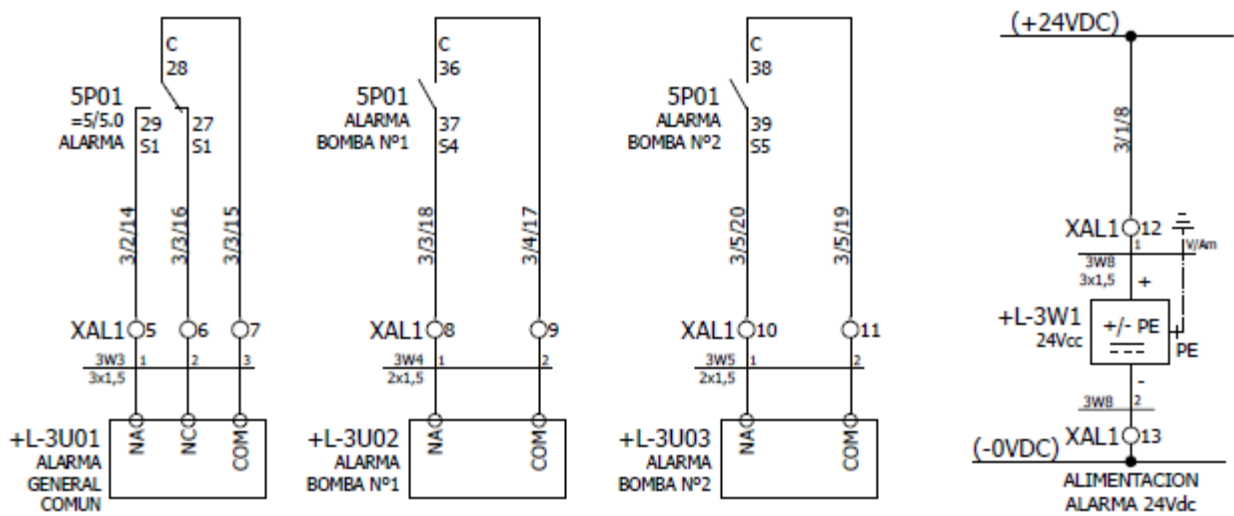

APC offers power output buzzer / light alarm ABS 9000056 or similar. As you can see in the figure above, connect the warning signal or you can use the floating signal is desired along with the terminals AL: + and AL: - Power to 24VDC.

The alarm output contact type controller is switched, having a closed contact between terminals 28 and 27 PC242 (called AL: AL 3 and 4 in the table). This output is programmed to switch if there is no alarm on it so that if a device is connected alarm signalling (acoustic / light, picture, etc..) Indicate an alarm both as a power failure or breakdown in PC242 (for would contact their state of rest: NC).

---

**4. RECOMMENDED DOCUMENTS FOR READING**

---

---

**4.1 ELECTRICAL DRAWING**

---

---

**4.2 FORM TO REGISTER PC242 SETTINGS**

---

---

**4.3 USER GUIDES FOR DEVICES RELATED TO APC CONTROL PANELS**

---

- A. LEVEL SENSORS MD124 / MD126 / MD127: USER AND INSTALLATION GUIDE
- B. PC242 PUMP CONTROLLER INSTALLATION GUIDE
- C. PC242 PUMP CONTROLLER USER GUIDE
- D. PC242 PUMP CONTROLLER COMLI/MODBUS REGISTER GUIDE

---

**5. DECLARATION CONFORMITY**

---

## Sulzer Pumps Wastewater Spain, S.A.

Declare under our sole responsibility that the products:

C.Eléctrico APC 2B / APC 2B Control panel, with references:

84004263/84004264/84004265/84004266/84004307  
84004308/84004511/84004512/84004513/84004514  
84004515/84004516/84004517/84004518/84004519  
84004520/84004521/84004522/84004523/84004524

To which this declaration relates are in conformity with the following standards or other normative documents:

IEC 158-1/2  
IEC 364-1 -> 7  
IEC 255-1  
IEC 408  
IEC 337-1  
IEC 204-1/2  
IEC 158  
IEC 292  
CE 73/23  
CE 89/336

Date

Signed

---

30 - 08 - 2016

  
Sulzer Pumps Wastewater Spain, S.A.  
C/ Madera, 4 - 16,  
Pol. Ind. Santa Ana  
28522 Rivas-Vaciamadrid  
Madrid